

< Features >

- * **Low Noise Temperature**
 - Noise Temperature: 15 K
- * **Low DC Current Drain**
 - DC Current Drain: 125 mA
- * **Small Size & Light Weight**
 - Weight: 800 g
- * **RoHS Compliance**

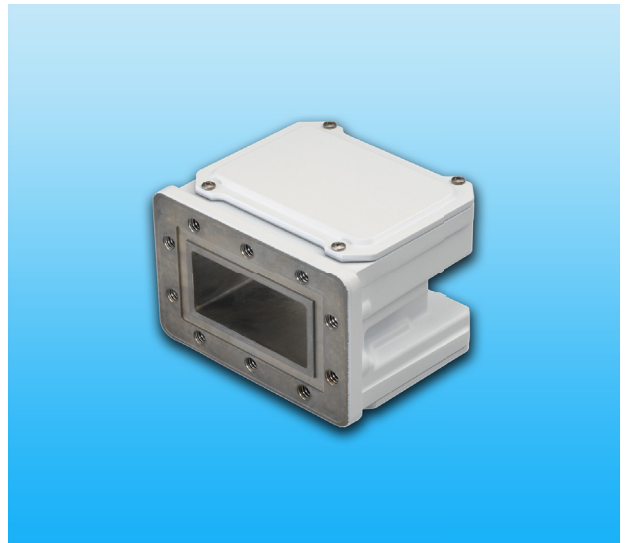

< Line-Up >

Model No.	RF Frequency	IF Connector	Power Supply
NJS8452	3.400 to 4.200 GHz (Palapa C-band)	N-type	+24 VDC (+12 to +28 VDC)
NJS8451	4.500 to 4.800 GHz (Insat C-band)		

< Specifications >

Item	Specifications
Input Interface	Waveguide, CPR229 (with Groove)
Output Interface	N-type, female (50 ohm)
Noise Temperature (Ta.: +25 °C)	15 K typ., 30 K max.
Linear Gain (Ta.: +25 °C)	48 dB min., 55 dB max. [Model No.: NJS8452] 55 dB min., 62 dB max. [Model No.: NJS8451]
Input V.S.W.R.	3.0 : 1 typ.
Output V.S.W.R.	2.0 : 1 max.
Power Requirement	+24 VDC (+12 to +28 VDC)
Current Drain	125mA typ., 160 mA max.
Temperature Range (ambient)	-40 to +60 °C (operating), -40 to +80 °C (storage)
Waterproof/Dustproof (IP Code)	IP 67
Dimension & Housing (without Interface Connectors)	80.8 mm (L) x 99.6 mm (W) x 76 mm (H) [3.18" (L) x 3.92" (W) x 2.99" (H)]
Weight	800 g [1.76 lbs]

■ C-band LNA

MODEL No. NJS8451 & NJS8452

< Outline Drawing >

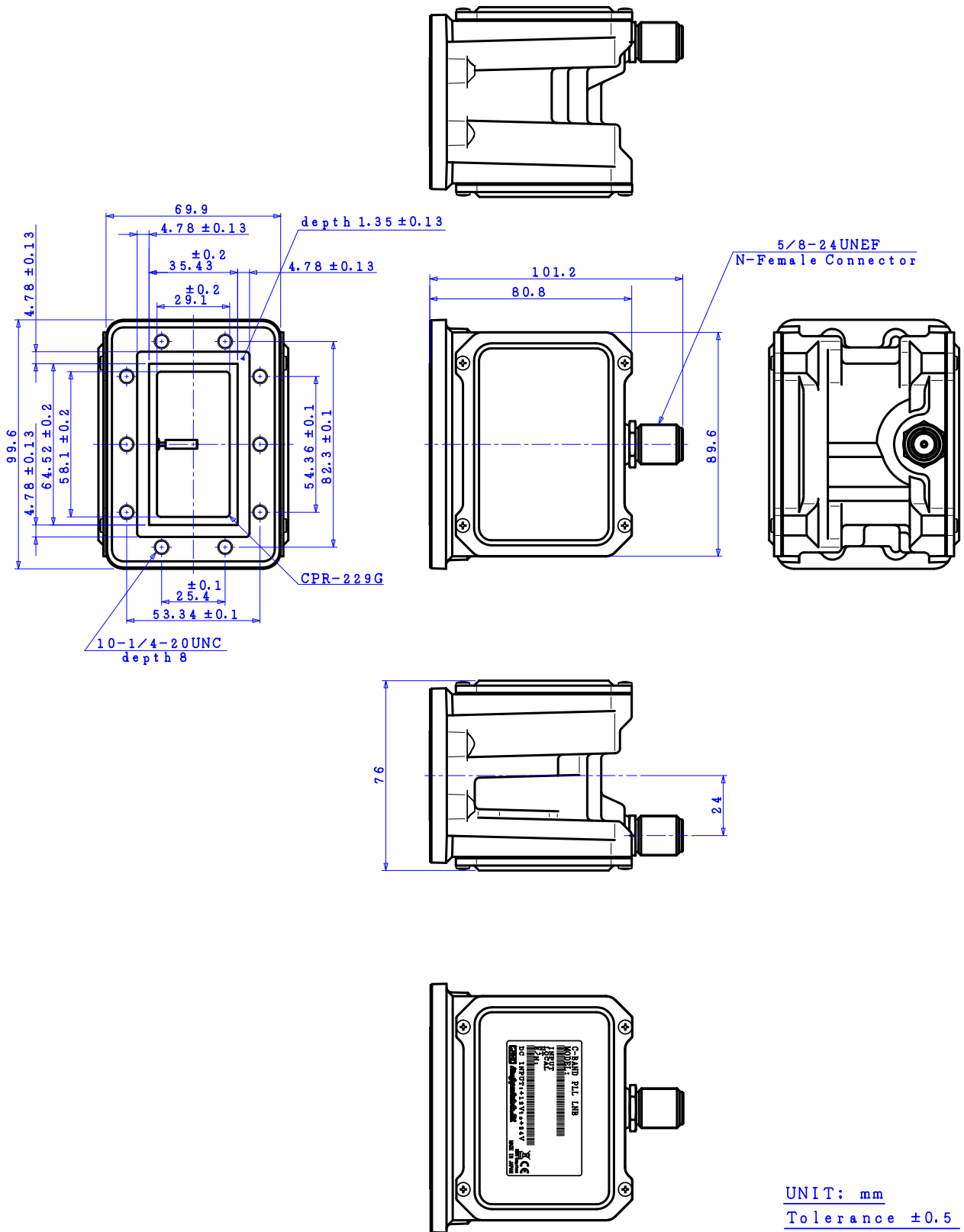

UNIT: mm
Tolerance ±0.5

*Note: The contents of this sheet are subject to change without notice.