

Released

- Specification -

Outdoor

500W AC/DC

Power Supply Unit(PSU)

Model No. NJZ1295

Input AC Voltage Range: 100 to 240 V

Output DC Power: 500 W

Output DC Voltage: +51 VDC

Copyright©

Nisshinbo Micro Devices Inc.

Microwave Business Division

-Notice of Proprietary Information-

This document and its contents are proprietary to Nisshinbo Micro Devices Inc.

This publication and its contents may not be reproduced or distributed for any other purpose
without the written permission of Nisshinbo Micro Devices Inc.

Those specifications listed in this document are subject to change at any time.



Caution

1. While Nisshinbo Micro Devices Inc. (NISD) continually strives to improve the quality and reliability of our products, failures will occur in microwave products over time. For this reason, it is important that customers fulfill their responsibilities to ensure designed-in safety – including failsafe functions, redundancy, and measures to prevent malfunctions and the spread of fire – in order to avoid injuries, accidents, or social repercussions resulting from the failure of any products related to satellite communications on this document (hereinafter, “the product”). Customers must pay careful attention to ensuring the safety of their equipment.
2. The product is designed and tested to function in accordance with its specifications. Do not use under conditions that deviate from the product specifications included in the delivery specifications. NISD assume no responsibility and shall not be liable for any injuries, accidents, or social repercussions resulting from the product being in a poor or damaged state because it was used under conditions that depart from the specifications.
3. The product is covered by a warranty for one year following delivery unless otherwise stipulated in the contract or delivery conditions. In the event of a failure for which NISD are responsible occurring during the warranty period, NISD undertake to repair or replace the product free of charge. Note, however, that the warranty does not cover failures such as those listed here (see bullets below), even if they occur within the warranty period. In addition, in the case of a product being repaired or replaced by us, the starting date for the warranty period is still the original delivery date of the product.
 - Failure due to the product being used in conditions other than those stipulated in the data sheet, specification sheet, etc.
 - Failure due to modifications or repairs carried out by some entity other than our company
 - Failure determined to be the result of unsuitable maintenance or replacement of a consumable item that requires due maintenance
 - Failure due to circumstances that were unforeseeable given the scientific/technological standards at the time of shipment
 - Other failures due to external factors such as fire, earthquake, flood and power supply anomalies for which NISD are not responsible

In addition, the product warranty is limited to the provision of repair services or replacement at no cost. It does not cover secondary damage (to equipment, business opportunities, profits, etc.) or any other damage that may have resulted from failure of the product.

4. The product must be handled appropriately to ensure its continued reliability. Since it can be damaged by the intrusion of water, dust, oil, chemicals, etc., it must be given appropriate protection. Even in the case of a product with an airtight construction, avoid using it in an environment that exceeds the stated levels of waterproofing/dustproofing. Also, be sure to use connectors and waveguides properly.
 If replacement parts such as fans are included, proper maintenance is necessary. To maintain product performance and functionality, it is necessary to conduct inspections and maintenance at appropriate intervals and exchange replacement parts when necessary. Improper inspections or maintenance may result in failure.
 In addition, the warranty does not cover the use of the product in areas where salt damage can be expected or where there is a substantial presence of corrosive gases such as Cl₂, H₂S, SO₂, and NO₂. If the product is to be used in such areas, at the time of installation you must take appropriate steps to protect the product.
5. If the product is to be used with equipment/systems that must meet special quality and reliability standards (aerospace equipment, medical equipment, power generation control equipment, automotive/railway transportation equipment, safety equipment, disaster prevention and security equipment, etc.), please consult with our sales staff in advance.
6. Some products contain gallium arsenide (GaAs), classified as a harmful substance. To avoid danger, do not incinerate, crush, or chemically treat the product in such a way that gases or dust are released. When disposing of the product, comply with all applicable laws and regulations and do not treat it as general industrial waste or household waste.
7. When exporting a product or technology, observe export laws and regulations such as those governing foreign exchange and foreign trade, and obtain any necessary licenses for export, service transactions, etc.
 NISD request that you do not use our products or the technical data published on this document for developing weapons of mass destruction or for any other military purposes or applications.
8. The product specifications in this document are subject to change without notice. If you are considering using a product, delivery specifications must first be settled.

* Above Specifications are subject to change without notice.

Scope

This Power Supply Unit(PSU) is intended for the satellite communication data uplink application in C-band and Ku-band.

The features of the PSU are to provide the stable +51V DC power with up to 500W capacity to use the high power BUCs of DC power operation. The unit employs the aluminum housing with corrosion-proof treatment on the surface and has waterproof and dust-proof constructor in order to use perfectly as the outdoor unit.

In addition the PSU complies with EC DIRECTIVE.

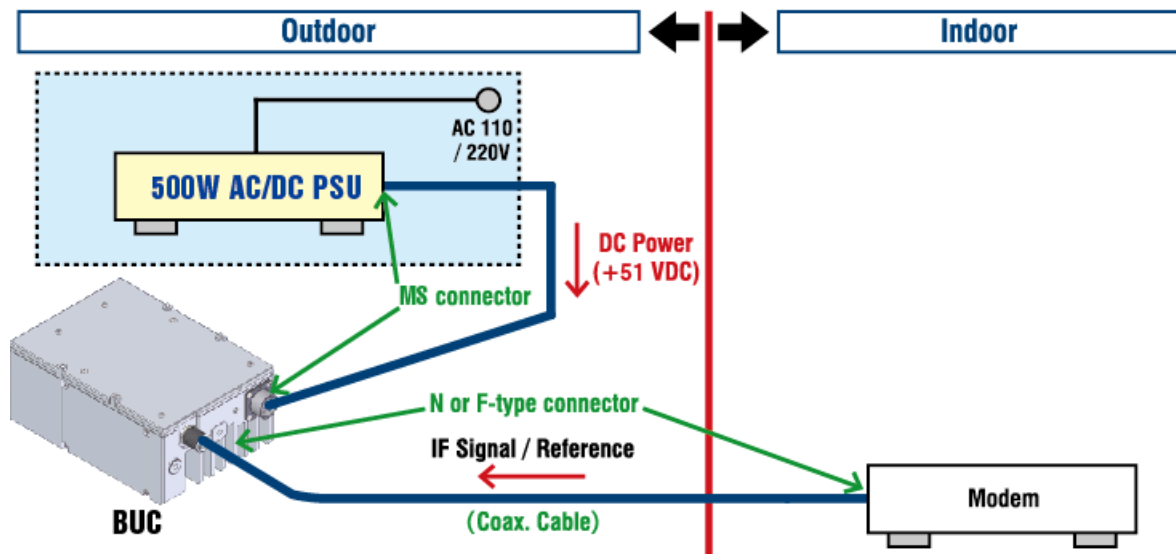

Fig.1 Connection Block Diagram

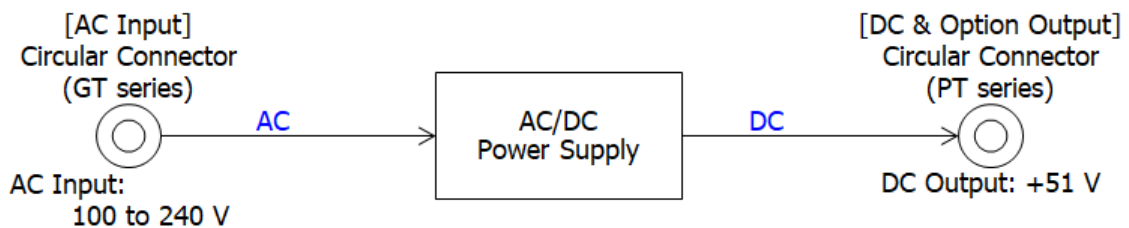

Fig.2 Functional Block Diagram

* Above Specifications are subject to change without notice.

Series Model Number

- Line-up

Model No.	Output DC Voltage	Output DC Capacity	Cooling Type	Usage Type
NJZ1289	+48 V nom.	250 W max.	Convection Air Cooling	Outdoor
NJZ1295	+51 V nom.	500 W max.	Forced-air-cooled by Fan	

* Above Specifications are subject to change without notice.

1. Electrical Specifications

#	Items	Specifications
1.1.	Input AC Voltage Range [Rated Range] [Absolute Maximum Rating]	100 to 240 VAC 90 to 264 VAC
1.2.	Input AC Frequency Range	50/60 Hz
1.3.	Input AC Current	6 A max. @ 110 V Input 3 A max. @ 230 V Input
1.4.	Output Voltage	+51 VDC +/- 3 V
1.5.	Output Current	9.8 A max. (Output: +51 V / 500 W Load) @110 V / 230 V Input <small>*Note 1</small>
1.6.	Efficiency	85 % typ. @ 110 V Input & 500 W Load 88 % typ. @ 230 V Input & 500 W Load <small>*Note 2</small>
1.7.	Maximum Output Power	500 W at 110 V / 230 V Input <small>*Note 1</small>
1.8.	Power Factor	0.96 typ. @ 110 V Input & 500 W Load 0.93 typ. @ 230 V Input & 500 W Load <small>*Note 2</small>

*Note1: The detail refers to a graph of the output power derating curve in below.

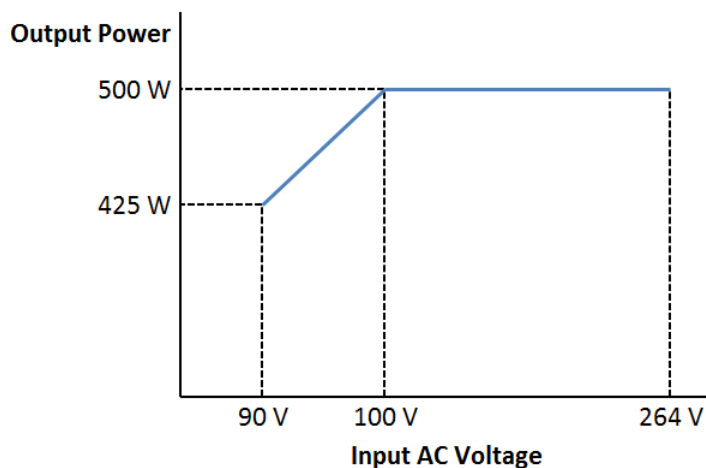

*Note2: The condition is 110 and 230 VAC as AC voltage input and no fan rotation.

* Above Specifications are subject to change without notice.

2. Mechanical Specifications

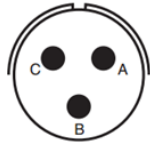
#	Items	Specifications
2.1.	Input Interface <div style="text-align: right;">[AC Input]</div>	Unit Connector: GTS030-16-10P (025) Mating Connector: GTS06CF-16-10S (025) <div style="text-align: right;">[Amphenol GT Connector]</div> Assignment: <div style="display: flex; align-items: center; justify-content: center;">  <div style="margin-left: 20px;"> Pin A: AC input (Live) Pin B: Frame Ground (GND) Pin C: AC input (Neutral) </div> </div>
2.2.	Output Interface <div style="text-align: right;">[DC Output]</div>	Unit Connector: PT02E-12-3P (025) Mating Connector: PT06E-12-3S (470) <div style="text-align: right;">[Amphenol PT Connector]</div> Assignment: <div style="display: flex; align-items: center; justify-content: center;">  <div style="margin-left: 20px;"> Pin A: DC Output (+) / Prime Pin B: Frame GND Pin C: DC Output (-) / Return </div> </div>
2.3.	Dimension & Housing without Interface Connectors and Screws	250 (L) x 191 (W) x 118.1 (H) mm [9.84" (L) x 7.52" (W) x 4.65" (H)]
2.4.	Weight	5.0 kg [11 lbs.]
2.5.	Surface Finish <div style="text-align: right;">[Protective & Conformal Coating]</div> <div style="text-align: right;">[Finish Paint]</div>	Trivalent Chromate Treatment Acrylic Paint, Ivory Color
2.6.	Cooling	Forced-air-cooled

* Above Specifications are subject to change without notice.

3. Environmental Specifications

#	Items	Specifications
3.1.	Temperature Range (Ambient) [Operating] [Storage]	-40 to +60 °C -40 to +75 °C
3.2.	Humidity	0 to 100 %Rh
3.3.	Altitude	15,000 feet (4,572 m)
3.4.	Vibration (Survival)	3.2 G [31.3 m/s ²] (3 axis, 10 Hz to 1 kHz) 1 mm p-p (3 axis, 5 to 50 Hz)
3.5.	Shock (Survival)	30 G [294.2 m/s ²] (3 axis)
3.6.	Dust/Waterproof (IP Code Rating)	IP67 ^{*Note 3}
3.7.	Regulations	EU Directive (CE Marking) EMC - 2014/30/EU Low Voltage - 2014/35/EU RoHS - 2011/65/EU + (EU)2015/863
3.8.	Compliance Standard [Safety] [EMC]	IEC60950-1:2005+A1:2009+A2:2013 EN60950-1:2006+A11:2009+A1:2011+A12 :2012+A2:2013 Category and Group: Overvoltage Category: II Pollution Degree: 1 Material Group: IIIab EN61000-3-2 (Harmonic Current Emission Test) EN61000-3-3 (Voltage Fluctuations and Flicker Test) EN61000-4-2 (ESD Test) EN61000-4-3 (Radio-Frequency Electromagnetic Field Test) EN61000-4-4 (Electrical Fast Transient/Burst Test) EN61000-4-5 (Surge Test) EN61000-4-6 (Conducted Disturbance Radio-Frequency Test) EN61000-4-8 (Power Frequency Magnetic Field Test) EN61000-4-11 (Voltage Dips and Interruptions Test) EN55032-B (Disturbance Voltage Test)
3.9.	MTBF (by Method of Parts Count Reliability Prediction)	100,000 hours and more at +60 °C as Design Condition

*Note3: Conditioned on connection with all of enclosed mating connectors.

* Above Specifications are subject to change without notice.

4. Outline Drawing

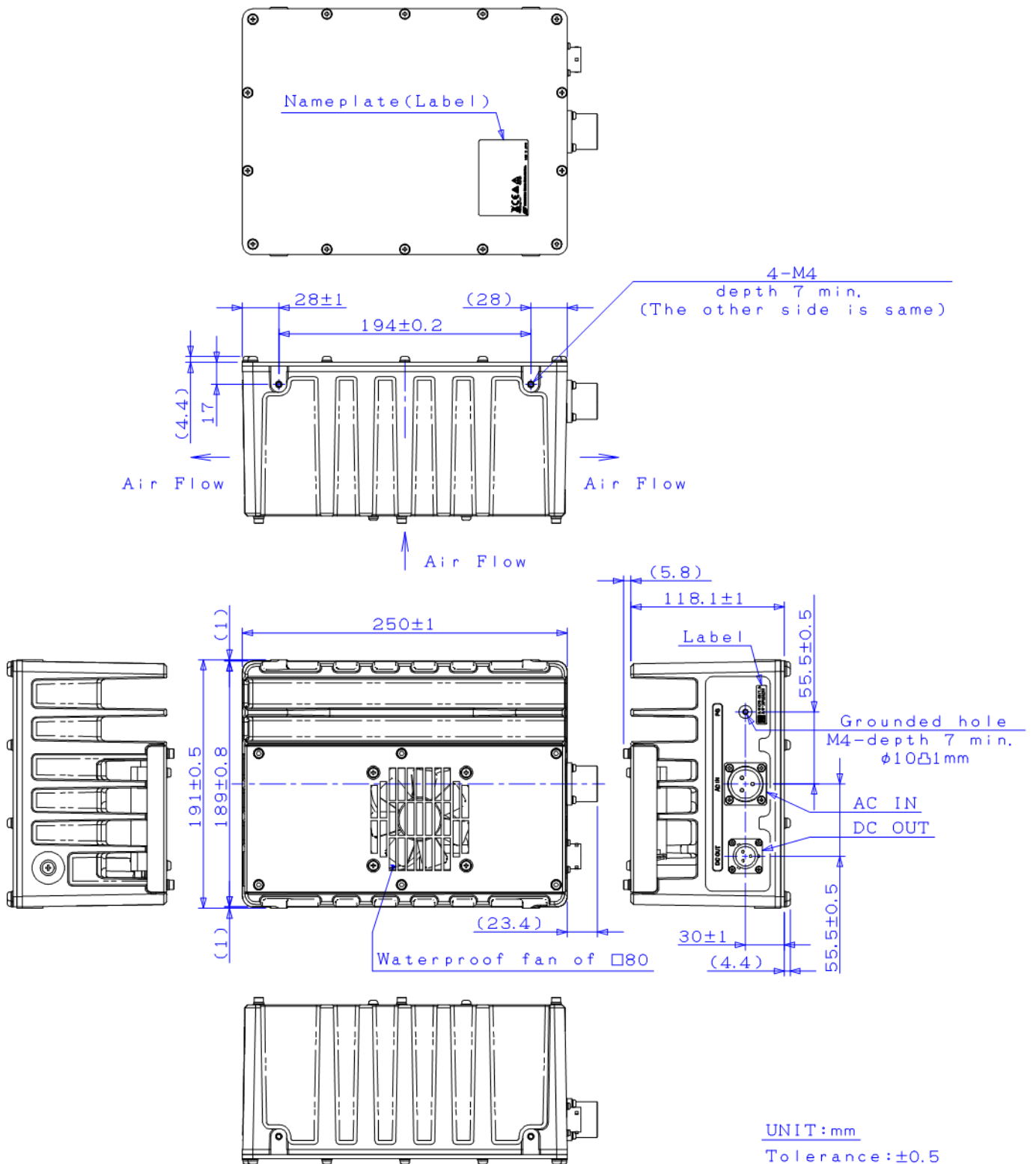

* Above Specifications are subject to change without notice.

CAUTION

Items	Description
Hot Surface	Whole of body and heat sink is hot when this unit is powered, and even after power is disconnected until it is cooled down. Do not touch hot surface to avoid a burn hazard.
Waterproof	Install all of mating connectors correctly and securely. Do seal all of cable connection points from the connector to the cable sheath by usage of self-amalgamating tape.
Fan Rotation	Do not insert finger into the fan in every case and time to avoid injury also do not insert any objects into the fan. Keep any objects away from the fan. Incorrect usage may cause injury to self or others.

* Above Specifications are subject to change without notice.

5. Label

5.1. Label Outline

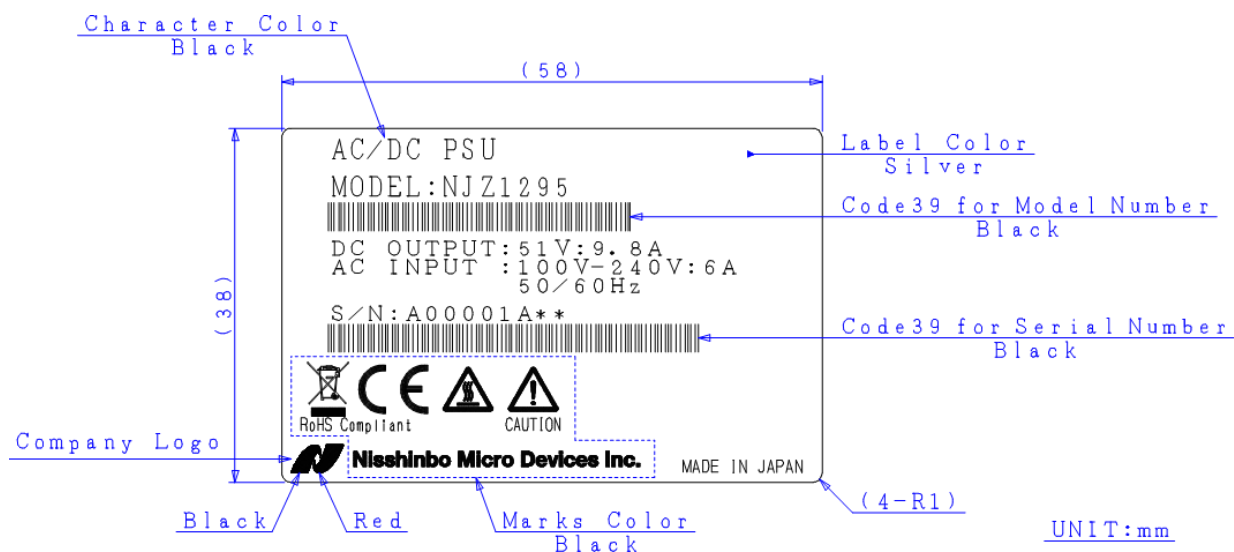

5.2. Definitions

Serial Number (OSSSSSRYM) - ALPHANUMERIC (9 characters)

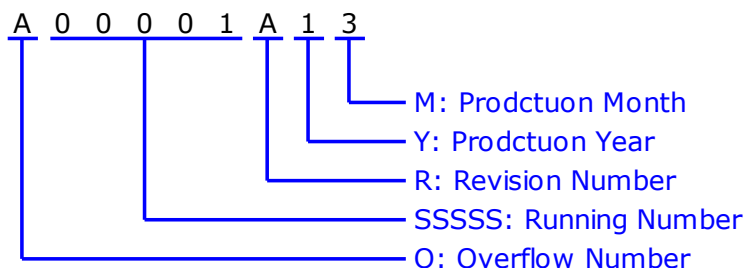

O: Overflow Number - ALPHABET (1 character)

"A" to "T" except "I" and "O", e.g.: A99999 ⇒ B00001

"V" to "Z": Specified Numbers

SSSSS: Running Number - NUMBER (5 digits)

"00001" to "99999"

R: Revision Number - ALPHABET (1 character)

"A" to "Z" except "I", "O", and "U"

Y: Production Year - NUMBER (1 digit)

"0" to "9", Last Digit of Calendar Number

e.g.: 2021:"1", 2022:"2", 2023:"3".....

M: Production Month - ALPHANUMERIC (1 character)

"1" to "9", "X" as October, "Y" as November, "Z" as December

* Above Specifications are subject to change without notice.

6. Package

6.1. Shipping Package

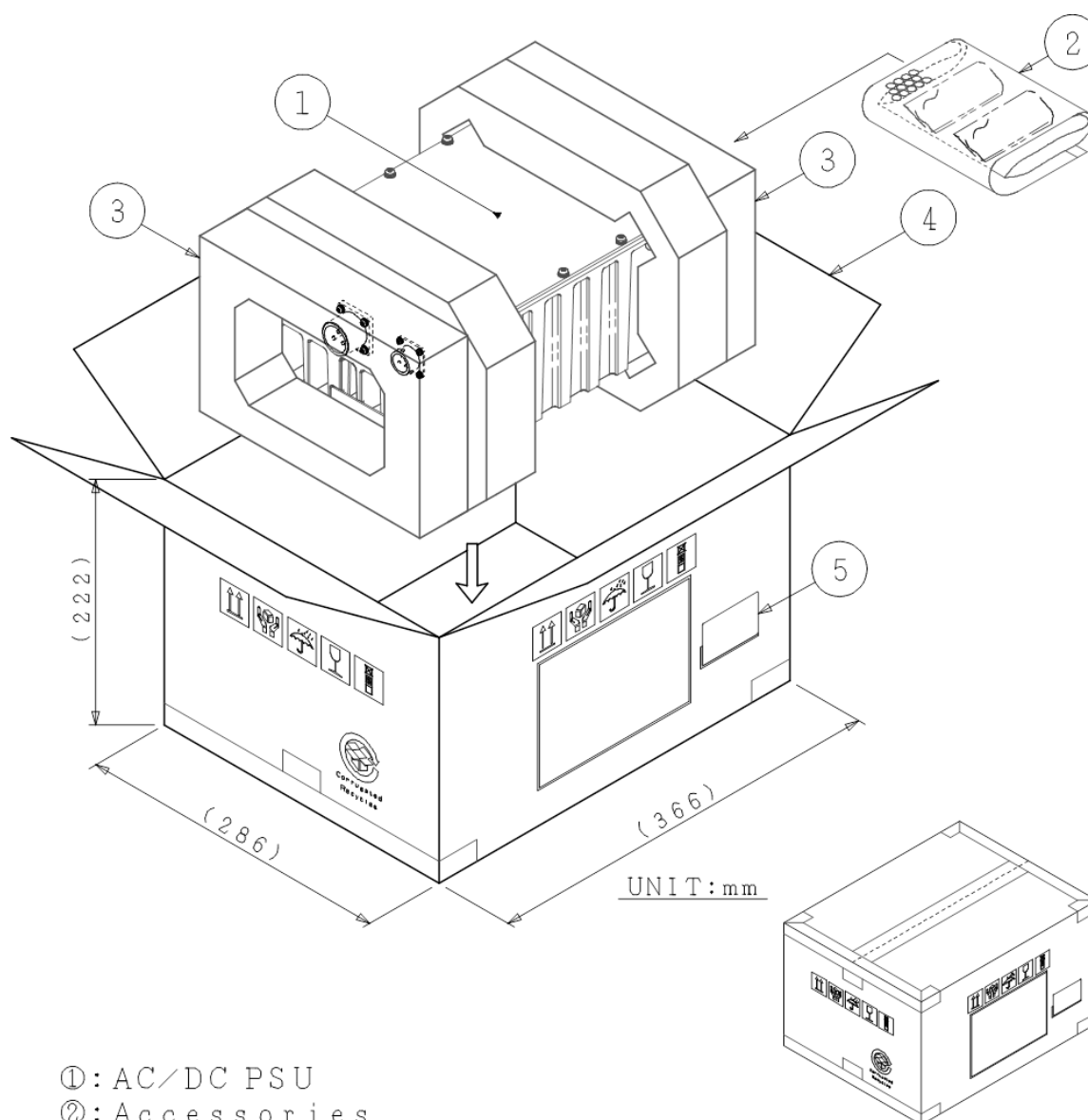

①: AC/DC PSU

②: Accessories

- AC mating connector
GTS06CF16-10S(025)

- MS mating connector
PT06E-12-3S(470)

③: Polyethylene foam for package cushioning

④: Double-faced corrugated fiberboard

⑤: Label

* Above Specifications are subject to change without notice.

6.2. Enclosed Accessories

- Circular Connector, Qty (1), Mating Connector for AC Input, GTS06CF-16-10S (025) [Amphenol GT Connector]
- Circular Connector, Qty (1), Mating Connector for DC Output, PT06E-12-3S (470) [Amphenol PT Connector]

* Above Specifications are subject to change without notice.

7. Handling Precautions

7.1. DANGER



This statement indicates an imminently hazardous situation which, if not avoided, will result in death or serious injury.

Items	Description
Input Voltage	Only input a AC voltage within the range indicated in specifications. <u>Do</u> operate with the input voltage range between 100 and 240 V AC power with 50/60 Hz of AC frequency. When applying higher voltage than specifications (264 V as absolute maximum rating), it will not only cause this unit failure, but it may also result in <u>electric shock</u> and <u>fire</u> .
Disassembling	<u>Do not</u> disassemble the unit. Disassembling will not only cause this unit failure, but it may also result in <u>electric shock</u> .

7.2. WARNING



This statement indicates a potentially hazardous situation which, if not avoided, could result in death or serious injury.

Items	Description
Hot Surface	Whole of body and heat sink is hot when this unit is powered, and even after power is disconnected until it is cooled down. <u>Do not</u> touch hot surface to avoid a burn hazard.

7.3. CAUTION



This statement indicates a potentially hazardous situation which, if not avoided, could result in minor or moderate injury. The statement may also be used to indicate other unsafe practices or risks of property damage.

Items	Description
Fan Rotation	<u>Do not</u> insert finger into the fan in every case and time to avoid injury also <u>do not</u> insert any objects into the fan. Keep any objects away from the fan. Incorrect usage may cause injury to self or others.
Connection	DC power of +51 V voltage will output at DC output interface connector. <u>Do not</u> connect the other than cable connected from the +51V operable BUC. The connected equipment may be damaged when cable connecting modem, the BUC other than the +51V operable BUC, or other equipment.

* Above Specifications are subject to change without notice.

7.4. NOTE

! N O T E

This statement is used to notify of installation, operation, or maintenance information that is important, but not hazard-related.

Items	Description
Mounting	<p><u>Do not</u> block airflow of this unit fan to keep the heat dissipation performance.</p> <p>The install direction and space mentioned at <u>Content 8.3.1</u> are recommended to secure.</p> <p>Normally the unit should be mounted with fan face down.</p>
Grounding	<p>To reduce the risk of damage or broken by lightning surge, the unit should be grounded by connecting the ground wire.</p>
Torque Management	<p><u>Do not</u> tighten with excessive torque when attaching screws/bolts.</p> <p>The following value as tighten torque is recommended.</p> <ul style="list-style-type: none"> ■ Screws/Bolts - M4: 1.52 ± 0.152 N·m
Weatherproof	<p>The unit mounted in outdoor should be conducted with adequately weatherproof procedure.</p> <p>Install all of mating connectors correctly and securely.</p> <p>Do seal all of cable connection points from the connector to the cable sheath by usage of self-amalgamating tape.</p>
Input Voltage	<p><u>Do</u> operate with the input voltage range between +100 and +240 V AC power.</p> <p>Avoid applying more than the maximum voltage in this range under any conditions.</p>
High Temperature Operation	<p>It may cause damage and/or degradation of reliability / lifetime to operate the unit in a condition where the ambient temperature exceeds the maximum value, <u>+60 °C</u>, at operating temperature described in the specifications.</p>
Vibration / Shock	<p>When vibration and/or shock impact exceeding the conditions described in the specifications is applied, internal parts may be damaged.</p>
Fan Maintenance	<p>The fan has its lifetime. The fan is to be replaced with a new one at appropriate interval.</p> <p>The recommendation interval of replacement is five(5) years.</p>
Warranty	<p>The unit is covered by a warranty for one(1) year following delivery unless otherwise stipulated in the contract or delivery conditions.</p> <p>Repairs may be possible under payment of charge even for the unit whose warranty period has expired.</p> <p>Opening, removing, disassembling and modifying any parts and components (including the product label, sealing tape and screws) without fan equipment will immediately void the warranty.</p> <p>In any case, the unit of invalid warranty cannot be repaired.</p>

* Above Specifications are subject to change without notice.

8. Instructions Manual

8.1. Descriptions

This section describes the information of Connectors and etc.

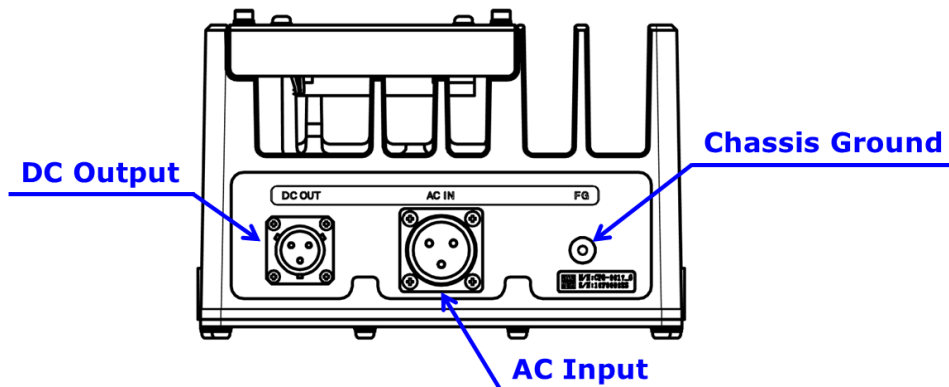

Items	Description	Purpose
AC Input	GTS030-16-10P(025) [Amphenol / 3 pins, male]	100 to 240 V AC power input.
DC Output	PT02E-12-3P(025) [Amphenol / 3 pins, male]	DC power (+51 V nominal) is output
Chassis Ground	M4 Screw Hole	Common chassis ground / frame ground.

8.2. Basic Connection Overview

e.g.) for Ku 40W BUC: NJT8371 series

8.2.1. Connection Overview between BUC and PSU

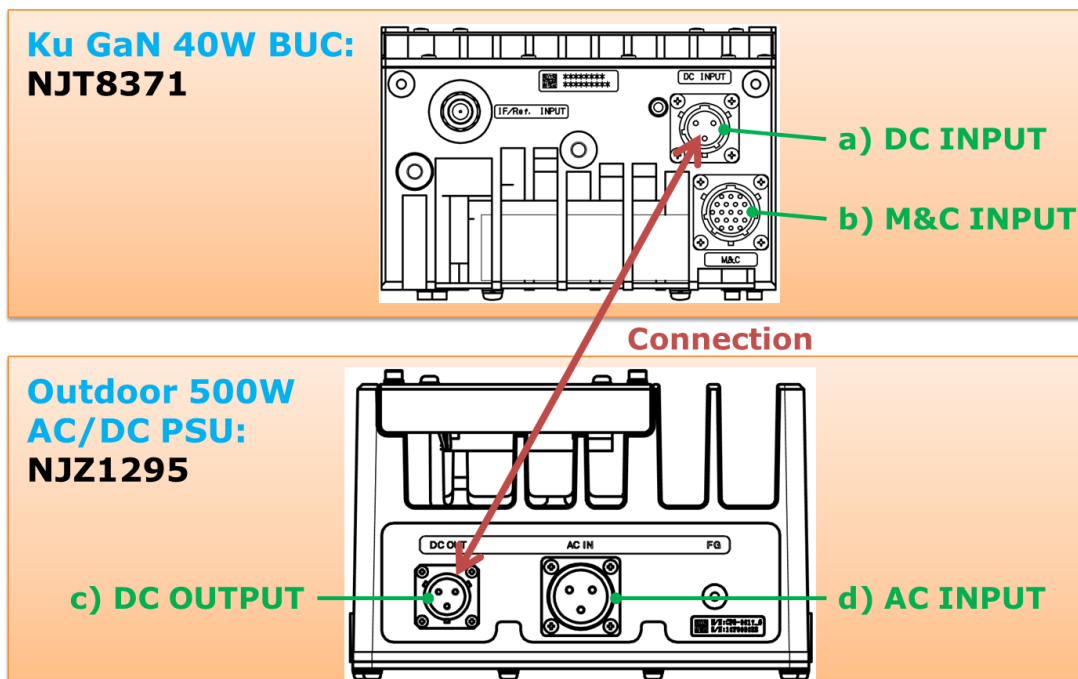

* Above Specifications are subject to change without notice.

8.2.2. Connector Pin Assignment

a) DC Input at NJT8371 (Ku 40W BUC)

Unit Connector: PT02E-12-3P(025) [Amphenol / 3 pins, male]

Mating Connector: PT06E-12-3S(470) [Amphenol / 3 sockets, female]

** Mating connector is enclosed in the shipping package of NJT8371*

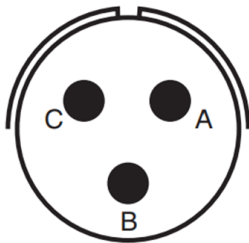

Pin No.	Item	Description
A	DC Input (+)	Prime: +36 to +60 V / DC Voltage
B	Frame GND	GND
C	DC Input (-)	Return

b) M&C Input at NJT8371 (Ku 40W BUC)

Unit Connector: PT02E-14-19P(025) [Amphenol / 19 sockets, male]

Mating Connector: PT06E-14-19S(470) [Amphenol / 19 pins, female]

** Mating connector is enclosed in the shipping package of NJT8371*

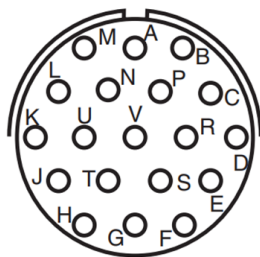

Pin No.	Item	Description
A	GND	GND
B	GND	GND
C	N.C.	-
D	N.C.	-
E	N.C.	-
F	RS-232C GND	RS-232C M&C Interface
G	RS-232C RxD	RS-232C M&C Interface
H	RS-232C TxD	RS-232C M&C Interface
J	N.C.	-
K	N.C.	-
L	N.C.	-
M	N.C.	-
N	N.C.	-
P	N.C.	-
R	N.C.	-
S	N.C.	-
T	N.C.	-
U	N.C.	-
V	N.C.	-

* Above Specifications are subject to change without notice.

c) DC Output at NJZ1295 (500W AC/DC PSU)

Unit Connector: PT02E-12-3P(025) [Amphenol / 3 pins, male]

Mating Connector: PT06E-12-3S(470) [Amphenol / 3 sockets, female]

* Mating connector is enclosed in the shipping package of NJZ1295

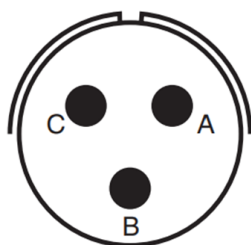

Pin No.	Item	Description
A	DC Input (+)	Prime: 51 V / DC Voltage
B	Frame GND	GND
C	DC Input (-)	Return

d) AC Input at NJZ1295 (500W AC/DC PSU)

Unit Connector: GTS030-16-10P(025) [Amphenol / 3 pins, male]

Mating Connector: GTS06CF-16-10S(025) [Amphenol / 3 sockets, female]

* Mating connector is enclosed in the shipping package of NJZ1295

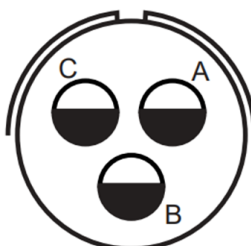

Pin No.	Item	Description
A	AC Input (Live)	100 to 240 V, AC Voltage
B	Frame GND	GND
C	AC Input (Neutral)	100 to 240 V, AC Voltage

8.3. Connection and Installation

This section describes basic installation for the PSU.

8.3.1. Setting

When installing the PSU, the following guidelines should be complied:

- ✓ Check factors such as accessibility, power, signal, and cable connections and future expansion on the installation location.
- ✓ Plan for access to connector side of the PSU.
- ✓ Ensure the location where the PSU operates has adequate ventilation around the fan intake and exhaust. Ambient air temperature may not cool the PSU to acceptable operating temperatures without adequate ventilation.
- ✓ Arrange the PSU with the install direction and space in below
- ✓ Available to use the mount bracket for $\Phi 76$ mast as option parts.

Install Direction and Space

* Above Specifications are subject to change without notice.

The install direction and space in accordance with following are recommended to secure and to keep the heat dispassion performance.

i) Install Direction

a) In case of "Horizontal Direction"

Cooling fan side shall be set to upward direction in below.

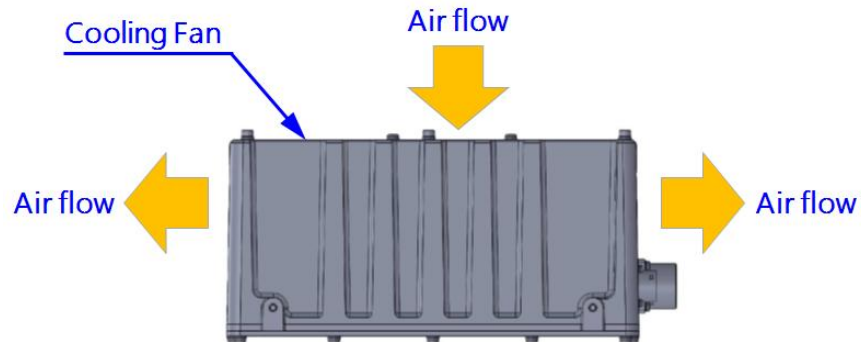

b) In case of "Vertical Direction"

Connector side shall be set to downward direction in below.

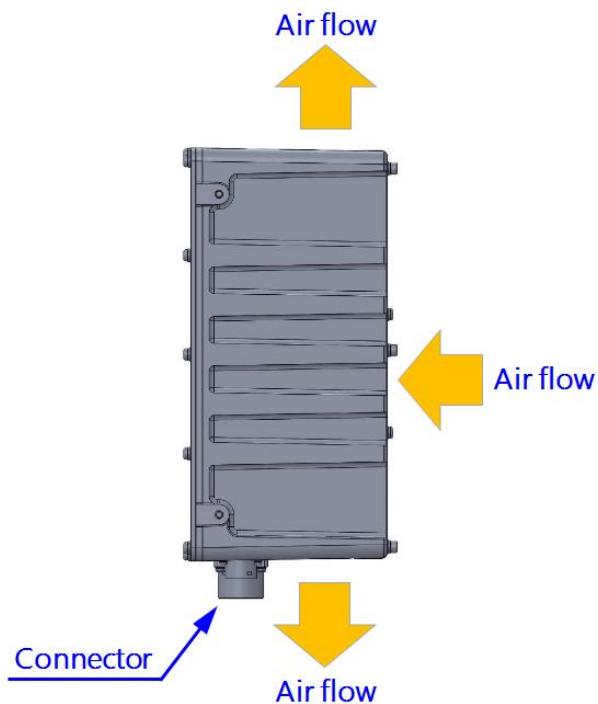

ii) Space

More than 30mm of space at least from inlet/outlet of cooling fan must be reserved.

! NOTE

- ✓ Do not block airflow of this unit fan to keep the heat dispassion performance.
The install direction and space mentioned are recommended to secure.

* Above Specifications are subject to change without notice.

8.3.2. Connection

Two cables and one wire:

- AC Power Cable
- DC Power Cable between the PSU and BUC
- Wire for Common Chassis Ground / Frame Ground

1) AC Power Cable

The PSU is directly powered by AC power source (100-240V). Low noise / low transient AC power source is recommended.

The connection of AC power cable should be complied with the following steps:

Step 1: Assemble the AC power cable. Use a power cable with an outer diameter (O.D.) of 9 - 13 mm to properly assemble the mating connector (Model: GTS06CF-16-10S(025)) included in the shipment package. The connector pin assignment should be referred in Item (d) of Section 8.2.2. The assembly method of mating connector is referred to appendix. The appropriate three-plug terminal should be selected according to the outlet shape to be used, and assembled to the power cable at the opposite side of the mating connector. It is available to purchase the AC power cable of P/N: NJZ1290A03 as option part.

Step 2: Connect the mating connector (Model: GTS06CF-16-10S(025)) of the AC power cable to the connector of AC Input of the PSU correctly and securely. And for to harden the waterproof structure it is recommended that a cable connection point from the connector to the cable sheath is sealed by usage of self-amalgamating tape.

Do not connect the AC power cable to the AC outlet before all of other connection steps.

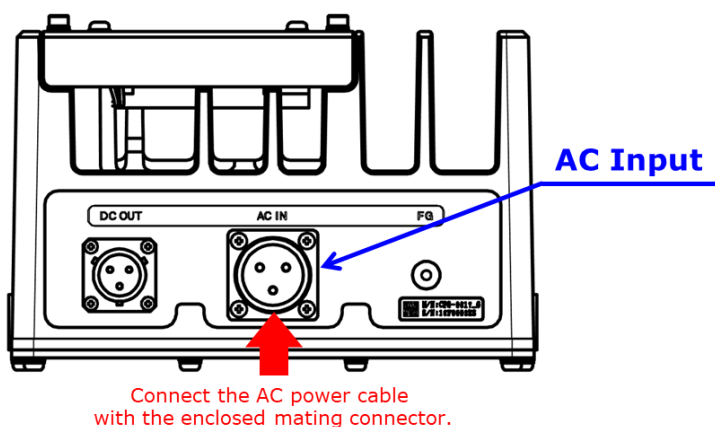

* Above Specifications are subject to change without notice.

2) DC Power Cable between the PSU and BUC

The PSU supplies +51V DC power to BUC through this connection cable.

The connection of the DC power cable between the PSU and BUC should be complied with the following steps:

Step 1: Assemble the DC power cable. Use a power cable with an outer diameter (O.D.) of 10.9 mm. The cable length should refer to Section 8.3.4, and for the decision of cable length it is needed to consider the voltage drop due to the conductor resistance of the wires. Properly assemble the mating connector (Model: PT06E-12-3S(470)) included in the shipment package of the PSU to the power cable. Properly assemble the mating connector (Model: PT06E-12-3S(470)) included in the shipment package of the BUC to opposite side of the aforementioned power cable. The pin assignment of connectors should be referred in Item (a) and (c) of Section 8.2. The assembly method of mating connector is referred to appendix.

It is available to purchase the DC power cable of P/N: NJZ1290A04 as option part.

Step 2: Connect the appropriate mating connector (Model: PT06E-12-3S(470)) of the DC power cable to the connector of DC Output at the PSU correctly and securely. And for to harden the waterproof structure it is recommended that a cable connection point from the connector to the cable sheath is sealed by usage of self-amalgamating tape.

Step 3: Connect the appropriate mating connector (Model: PT06E-12-3S(470)) of the DC power cable to the connector of DC Input at the BUC correctly and securely. And for to harden the waterproof structure it is recommended that a cable connection point from the connector to the cable sheath is sealed by usage of self-amalgamating tape.

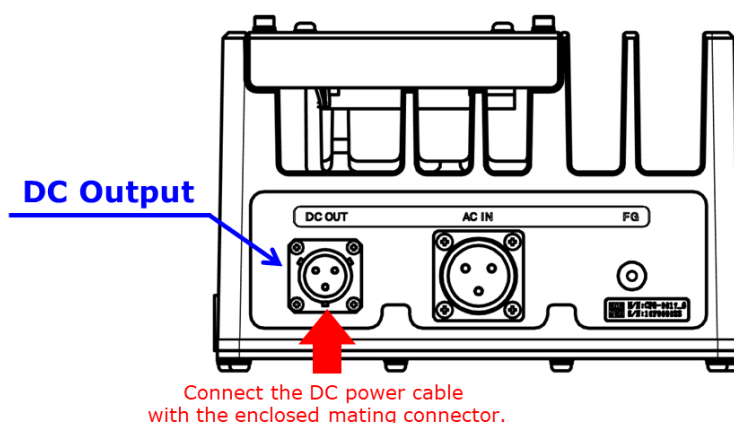

* Above Specifications are subject to change without notice.

3) Wire for Common Chassis Ground / Frame Ground

The PSU can be had the chassis ground of the other equipment (e.g. modem) in common.

Connecting wire for common chassis ground from the chassis ground of the other equipment should be complied with the following step:

Tools Required: #2 Phillips screwdriver

Step: Connect the wire from ground on the other equipment to the ground hole with M4 x 8 mm Philips pan head screw.

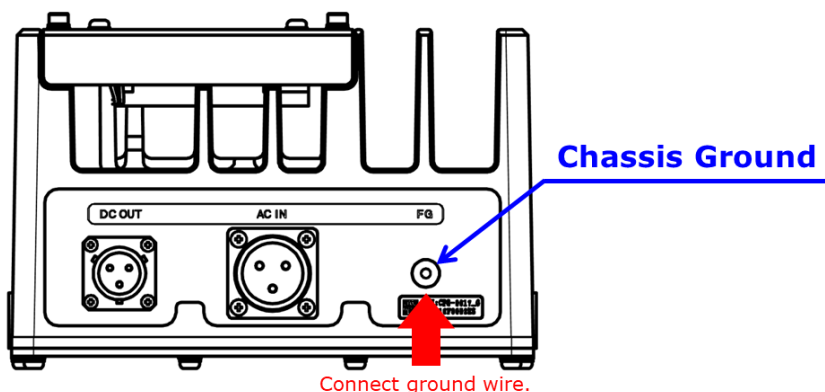

CAUTION

- ✓ DC power of +51 V will output at DC output interface connector. Do not connect the other than cable connected from the +51V operable BUC. The connected equipment may be damaged when cable connecting modem, the BUC other than the +51V operable BUC, or other equipment.



NOTE

- ✓ Do not connect the AC power cable to the AC outlet before all of other connection steps.
- ✓ To reduce the risk of damage or broken by lightning surge, the unit should be grounded by connecting the ground wire.
- ✓ Do operate with the input voltage range between +100 and +240 V AC power. Avoid applying more than the maximum voltage in this range under any conditions.
- ✓ Do seal all of cable connection points from the connector to the cable sheath by usage of self-amalgamating tape for to harden the waterproof structure

8.3.3. Start-up

Start-up will be immediately performed with the following step:

Step: Connect the AC power cable to the AC outlet

* Above Specifications are subject to change without notice.

8.3.4. Recommendation Cable between PSU to BUC

Type and length of the signal cable from the PSU to BUC need to be chosen to satisfy that the PSU output less than 500 W DC power, and an input voltage of BUC is more than input minimum voltage such as 36 V.

The chart for total resistance* and maximum length is referred in below.

BUC Model	DC Power Requirement of BUC		Total Resistance	Maximum Length		
	Minimum Input Voltage	Maximum Power Consumption		0.5 SQ Wire Cable	0.75 SQ Wire Cable	1.25 SQ Wire Cable
NJT8371 series	+36 V	290 W	1.8 Ω	---	34 m	56 m

(*Note: Total resistance means sum number of both prime wire and return wire resistance.)

8.4. Maintenance

This section describes basic maintenance for the PSU.

8.4.1. Dust Removal

Regular dusting / dust removal will ensure the PSU to operate within operational specification.

- ✓ Use a slightly damp cloth with excess moisture wringed out (not saturated, wet or dripping cloth) to wipe away the dust that collects on the outside of the enclosure
- ✓ A high, dusty environment will require frequent maintenance of vacuuming the dust off the enclosure vents and circuit board.

8.4.2. Fan Field Replacement

The PSU requires to flow forced-air by the installed fan on rear panel for cooling.

It is recommended that the fan is to be replaced with a new one at five years interval.

NOTE

✓ The fan has its lifetime. The fan is to be replaced with a new one at appropriate interval. The recommendation interval of replacement is 5 years.

The replacement of fan should be complied with the following steps:

Tools Required: Hex Wrench for M4 (size: 3 mm)

Parts Required: Replacement Fan - P/N: NJZ1290F06

* Above Specifications are subject to change without notice.

Step 1: Remove the hexagon socket head bolts (6 pieces) shown in Fig. 8.4.2.1.

These bolts are reused when installing the replacement fan. Please be careful not to lose them. When using different bolts, following equivalents should be used.

M4 x 8 Hexagon Socket Head Bolts with Washer and Spring W (SUS, Chrome plating treatment)

Step 2: Dismount the fan unit which is together with the fan and fan intake cover, and a fan connecting position should be checked (Refer to Fig. 8.4.2.2)

Do not pull the fan unit strongly because the fan cable is connected.

Step 3: Release the connector lock by pushing the locker hook in the direction of an arrow shown in Fig. 8.4.2.3.1.

Step 4: Pull out the fan cable from the connector in the direction of an arrow shown in Fig. 8.4.2.3.2.

Hold the connector body and pull it. Do not pull on the cable. When the connector lock is released normally, the connector can be pulled out with a weak force.

Step 5: After removing the fan unit in step 1-to-4, install the replacement fan unit in the reverse order of step 1-to-4

The connector shall be inserted securely until it is locked.

Recommended tighten torque of M4 bolts is 1.6 +/- 0.2 N·m.

Hexagon Socket Head Bolts

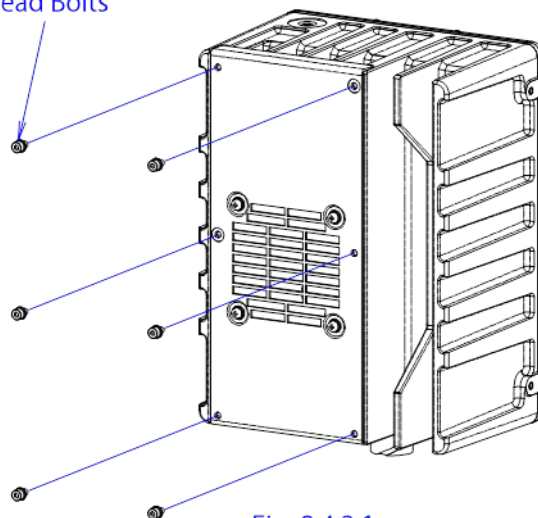
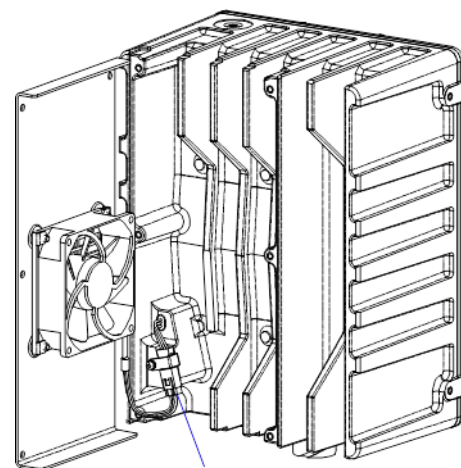

Fig. 8.4.2.1



Fan Connector

Fig. 8.4.2.2

Locker Hook

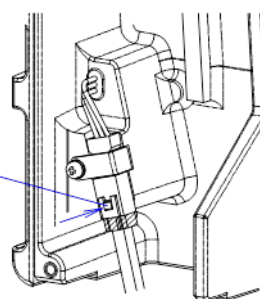

Fig. 8.4.2.3.1
(Connector Enlarged)

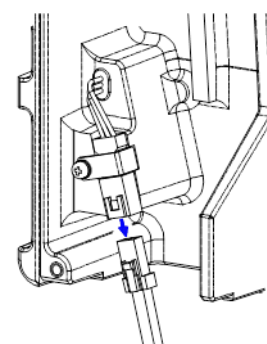

Fig. 8.4.2.3.2
(Connector Enlarged)

* Above Specifications are subject to change without notice.

9. Option Parts

9.1. AC Power Cable - P/N: NJZ1290A03

Connection Cable between the PSU (NJZ1295) and AC Outlet

- ✓ Length: 3m
- ✓ Weatherized Cable
- ✓ AC Mating Connector Assembled
- ✓ No Assembly at AC Outlet Side

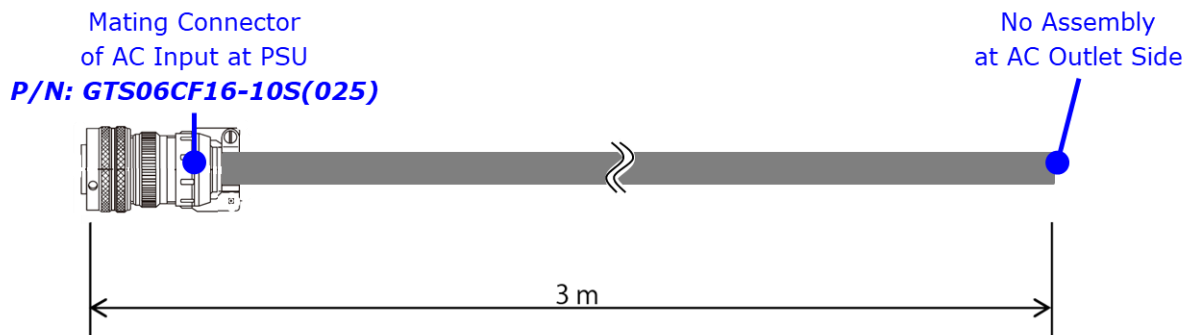

9.2. DC Power Cable - P/N: NJZ1290A04

Connection Cable between the BUC and the PSU (NJZ1295)

- ✓ Length: 5m
- ✓ Weatherized Cable
- ✓ Two Mating Connectors Assembled

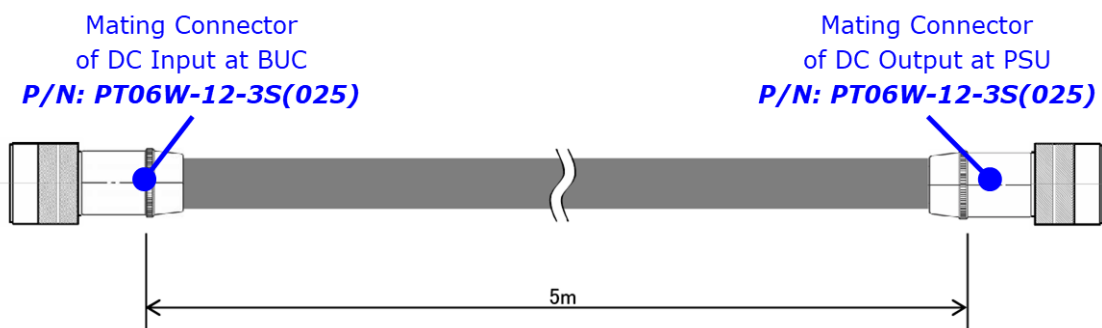

* Above Specifications are subject to change without notice.

9.3. Mount Bracket for $\Phi 76$ Mast - P/N: NJZ1290D04

This option part is to mount the PSU to $\Phi 76$ Mast.

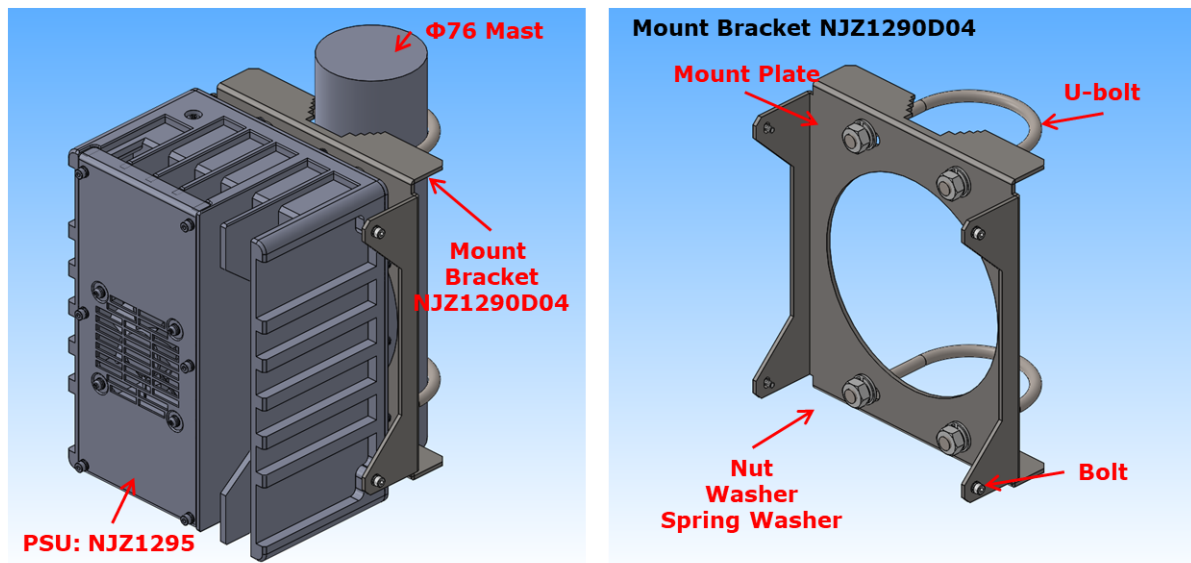

Item	Qty	Description
Mount Plate	1	SUS
Bolt	4	SUS, M4, with W & SW, for fixing PSU
U-bolt	2	SUS, 65A(2-1/2"), M10
Nut	4	SUS, M10
Washer	4	SUS, for M10
Spring Washer	4	SUS, for M10

9.4. Replacement Fan Kit- P/N: NJZ1290F06

This option part is to replace the cooling fan.

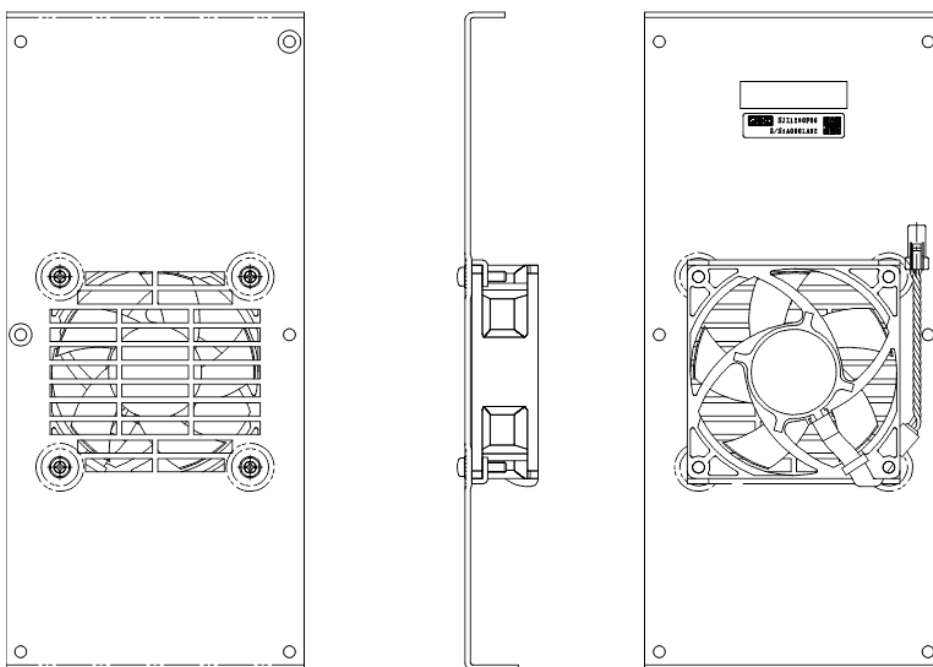

* Above Specifications are subject to change without notice.

This appendix mentions about cable assembly of mating connector.

Cable Assembly of Mating Connector
for GT Series and PT Series Connector

* Above Specifications are subject to change without notice.

1. Amphenol GT Series Connector

Applicable Connector:

- GTS06CF-16-10S(025) for AC Input at PSU

Assembly Procedure Steps:

Step 1: Prepare a signal cable with the wanted length. Use the cable with core wire conductor size and an outer diameter (O.D.) in below.



GTS06CF-16-10S(025)	
Layout / Pin Assignment (Mating face view of pin inserts)	
Contact Type:	 = #12
Shell Size	Shell-16
Contact Number	3 contacts - #12
Outer Diameter	9 to 13 mm
Contact Type	#12
Wire Size	AWG #12 to #14
Wire Stripping Length	10.5 mm

Table 1 Description of Connector / Cable / Wire

Step 2: Strip the outer sheath and filler with approx. 16.6 mm and strip the wire insulations with Wire Stripping Length by wire-stripper in Table 1. Treat the stripped wires with Rosin-flux of within-expired-date and immediately pre-solder the stripped wires with Rosin core solder.

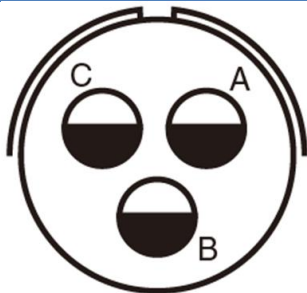

! NOTE

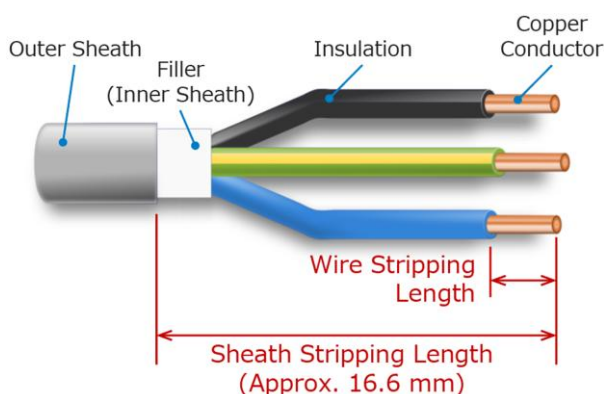
- ✓ Notice that any damage of the wire insulations when stripping the outer sheath and filler shall be avoided.

* Above Specifications are subject to change without notice.

Step 3: Disassembly a cable clamp, metal compression disc, neoprene sealing gland and backshell from the connector body. Do not disassembly a coupling nut, wave spring and skid washer form a barrel.

Insert the cable clamp, metal compression disc, neoprene sealing gland and backshell to the prepared AC power cable in the order of the cable clamp, metal compression disc, neoprene sealing gland and backshell.

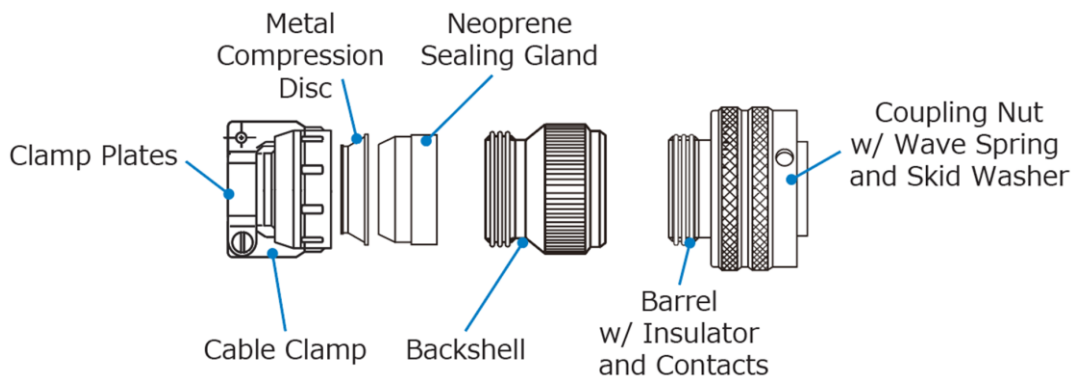

Step 4: Solder all of contacts and wires under condition with the pin assignment. It is recommended to arrange so that the contact cuts are upward for easy-soldering. Cleanse the flux at soldering points with ethyl-alcohol and etc.

!
NOTE

✓ Notice that insulator at the barrel shall be avoided to deform.

Step 5: Tighten the backshell to the barrel with following torque.
 Slide the neoprene sealing gland to the backshell until it hits the back of the backshell, and slide the metal compression disc to the neoprene sealing gland.
 Tighten the cable clamp to the barrel with following torque.
 Clamp the cable with two clamp plates, which will be fixed with enclosed flat head screws to the cable clamp.

Shell Size	Tighten Torque	Connector P/N
Shell-16	3.9 to 5.1 N·m	GTS06CF-16-10S(025)

* Above Specifications are subject to change without notice.

2. Amphenol PT Series Connector

Applicable Connector:

- PT06E-12-3S(470) for DC Output at PSU and DC Input at BUC

Assembly Procedure Steps:

Step 1: Prepare a signal cable with the wanted length. Use the cable with core wire conductor size and an outer diameter (O.D.) in below.

PT06E-12-3S(470)	
Layout / Pin Assignment (Mating face view of pin inserts)	
Contact Type:	
○ = #20	
● = #16	
Shell Size	Shell-12
Contact Number	3 contacts - #16
Outer Diameter	10.9 mm max.
Contact Type	#16
Wire Size	AWG #16 to #18
Wire Stripping Length	5.3 to 5.8 mm

Table 1 Description of Connector / Cable / Wire

Step 2: Strip the outer sheath and filler with up to 50 mm and strip the wire insulations with Wire Stripping Length by wire-stripper in Table 1. Treat the stripped wires with Rosin-flux of within-expired-date and immediately pre-solder the stripped wires with Rosin core solder.

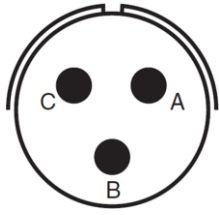
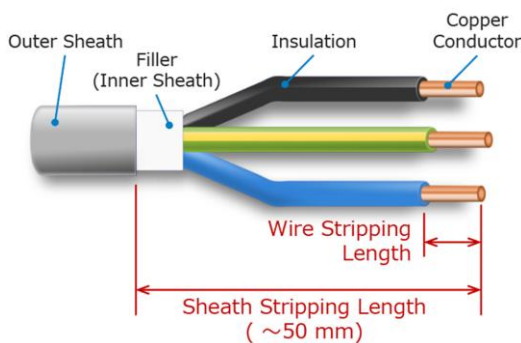

! NOTE

- ✓ Notice that any damage of the wire insulations when stripping the outer sheath and filler shall be avoided.

* Above Specifications are subject to change without notice.

Step 3: Disassembly a cable clamp, endbell, compression ring, and grommet from the connector body.

Insert the cable clamp, endbell, and compression ring to the prepared signal cable in the order of the cable clamp, endbell, compression ring.

Insert wires to the grommet under condition matched the pin assignment of contacts and wires.

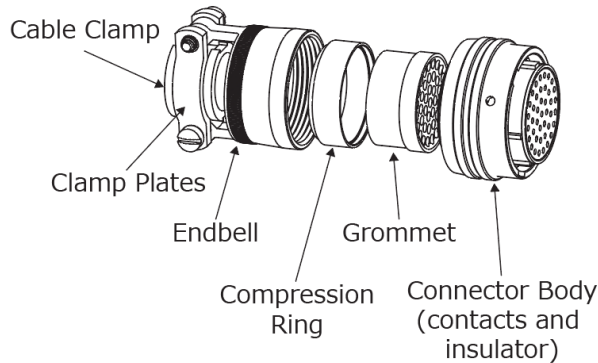

Step 4: Solder all of contacts and wires under condition with the pin assignment. It is recommended to arrange so that the contact cuts are upward for easy-soldering.

Cleanse the flux at soldering points with ethyl-alcohol and etc.

 NOTE
<p>✓ Notice that insulator of the connector body shall be avoided to deform.</p>

Step 5: Slide the grommet to the connector body until it hits the back of the insulator, and insert the compression ring to the step edge of the grommet.

Tighten the endbell to the connector body with following torque met for shell size.

Shell Size	Tighten Torque	Connector P/N
Shell-12	3.5 to 4 N·m	PT06E-12-3S(470)

When a gap between the cable clamp and wires is 1 mm or more, wrap wires at the cable clamp point with a self-amalgamating tape so that the gap is 1 mm or less. Set the cable clamp at wires of the cable clamp point. And clamp the cable clamp with two clamp plates, which will be fixed with enclosed flat head screws to the endbell.

Wrap both the cable and connector with a self-amalgamating tape from outer sheath of cable to the middle of endbell like as shown in the range of arrows in following image.



* Above Specifications are subject to change without notice.