

Released

- Specification -
Ku-band GaN 40W BUC
Model No. NJT8371 series

	RF Frequency	Local Frequency	IF Frequency
Universal Ku-band	13.75 to 14.5 GHz	12.8 GHz	950 to 1,700 MHz
Standard Ku-band	14.0 to 14.5 GHz	13.05 GHz	950 to 1,450 MHz

Saturation Output Power: +46 dBm (40W)

IF Input Interface: N-type / F-type, Female Connector

Ref. (10MHz) Input: IF Connector

DC Power Input: Circular Connector

RF Output Interface: Waveguide, WR-75

Power Supply: DC Power, +36 to +60 V DC

AC Power Operation, 100 to 240 V AC

M&C Option: FSK M&C / RS-232C Interface

Copyright©
Nisshinbo Micro Devices Inc.
Microwave Business Division

-Notice of Proprietary Information-

This document and its contents are proprietary to Nisshinbo Micro Devices Inc.
This publication and its contents may not be reproduced or distributed for any other purpose
without the written permission of Nisshinbo Micro Devices Inc.

Those specifications listed in this document are subject to change at any time.



Caution

1. While Nisshinbo Micro Devices Inc. (NISD) continually strives to improve the quality and reliability of our products, failures will occur in microwave products over time. For this reason, it is important that customers fulfill their responsibilities to ensure designed-in safety – including failsafe functions, redundancy, and measures to prevent malfunctions and the spread of fire – in order to avoid injuries, accidents, or social repercussions resulting from the failure of any products related to satellite communications on this document (hereinafter, “the product”). Customers must pay careful attention to ensuring the safety of their equipment.
2. The product is designed and tested to function in accordance with its specifications. Do not use under conditions that deviate from the product specifications included in the delivery specifications. NISD assume no responsibility and shall not be liable for any injuries, accidents, or social repercussions resulting from the product being in a poor or damaged state because it was used under conditions that depart from the specifications.
3. The product is covered by a warranty for one year following delivery unless otherwise stipulated in the contract or delivery conditions. In the event of a failure for which NISD are responsible occurring during the warranty period, NISD undertake to repair or replace the product free of charge. Note, however, that the warranty does not cover failures such as those listed here (see bullets below), even if they occur within the warranty period. In addition, in the case of a product being repaired or replaced by us, the starting date for the warranty period is still the original delivery date of the product.
 - Failure due to the product being used in conditions other than those stipulated in the data sheet, specification sheet, etc.
 - Failure due to modifications or repairs carried out by some entity other than our company
 - Failure determined to be the result of unsuitable maintenance or replacement of a consumable item that requires due maintenance
 - Failure due to circumstances that were unforeseeable given the scientific/technological standards at the time of shipment
 - Other failures due to external factors such as fire, earthquake, flood and power supply anomalies for which NISD are not responsible

In addition, the product warranty is limited to the provision of repair services or replacement at no cost. It does not cover secondary damage (to equipment, business opportunities, profits, etc.) or any other damage that may have resulted from failure of the product.

4. The product must be handled appropriately to ensure its continued reliability. Since it can be damaged by the intrusion of water, dust, oil, chemicals, etc., it must be given appropriate protection. Even in the case of a product with an airtight construction, avoid using it in an environment that exceeds the stated levels of waterproofing/dustproofing. Also, be sure to use connectors and waveguides properly.
If replacement parts such as fans are included, proper maintenance is necessary. To maintain product performance and functionality, it is necessary to conduct inspections and maintenance at appropriate intervals and exchange replacement parts when necessary. Improper inspections or maintenance may result in failure.
In addition, the warranty does not cover the use of the product in areas where salt damage can be expected or where there is a substantial presence of corrosive gases such as Cl₂, H₂S, SO₂, and NO₂. If the product is to be used in such areas, at the time of installation you must take appropriate steps to protect the product.
5. If the product is to be used with equipment/systems that must meet special quality and reliability standards (aerospace equipment, medical equipment, power generation control equipment, automotive/railway transportation equipment, safety equipment, disaster prevention and security equipment, etc.), please consult with our sales staff in advance.
6. Some products contain gallium arsenide (GaAs), classified as a harmful substance. To avoid danger, do not incinerate, crush, or chemically treat the product in such a way that gases or dust are released. When disposing of the product, comply with all applicable laws and regulations and do not treat it as general industrial waste or household waste.
7. When exporting a product or technology, observe export laws and regulations such as those governing foreign exchange and foreign trade, and obtain any necessary licenses for export, service transactions, etc.
NISD request that you do not use our products or the technical data published on this document for developing weapons of mass destruction or for any other military purposes or applications.
8. The product specifications in this document are subject to change without notice. If you are considering using a product, delivery specifications must first be settled.

* Above Specifications are subject to change without notice.

Scope

This BUC is designed for the block up-converter intended for the satellite communication data uplink application in Ku-band. It can transmit an RF signal (Ku-band: 14.0 to 14.5 GHz or 13.75 to 14.5 GHz) output with up to 40W (+46 dBm) saturated power. It is combined GaN and GaAs high power amplifiers and a block up-converter with a phase locked local oscillator (13.05 GHz or 12.8 GHz) which is synchronized with external 10MHz reference.

The BUC receives a reference signal (10 MHz) and an IF signal (L-band: 950 to 1,450 MHz or 950 to 1,700 MHz) input and transmits an RF signal (Ku-band: 14.0 to 14.5 GHz or 13.75 to 14.5 GHz) output. It is operated by +48 V DC power (Range: +36 to +60 V) input.

The BUC comes in a single, weatherized housing rated for outdoor use and has either an N-Type or F-type female connector as IF input, a WR-75 waveguide flange as RF output.

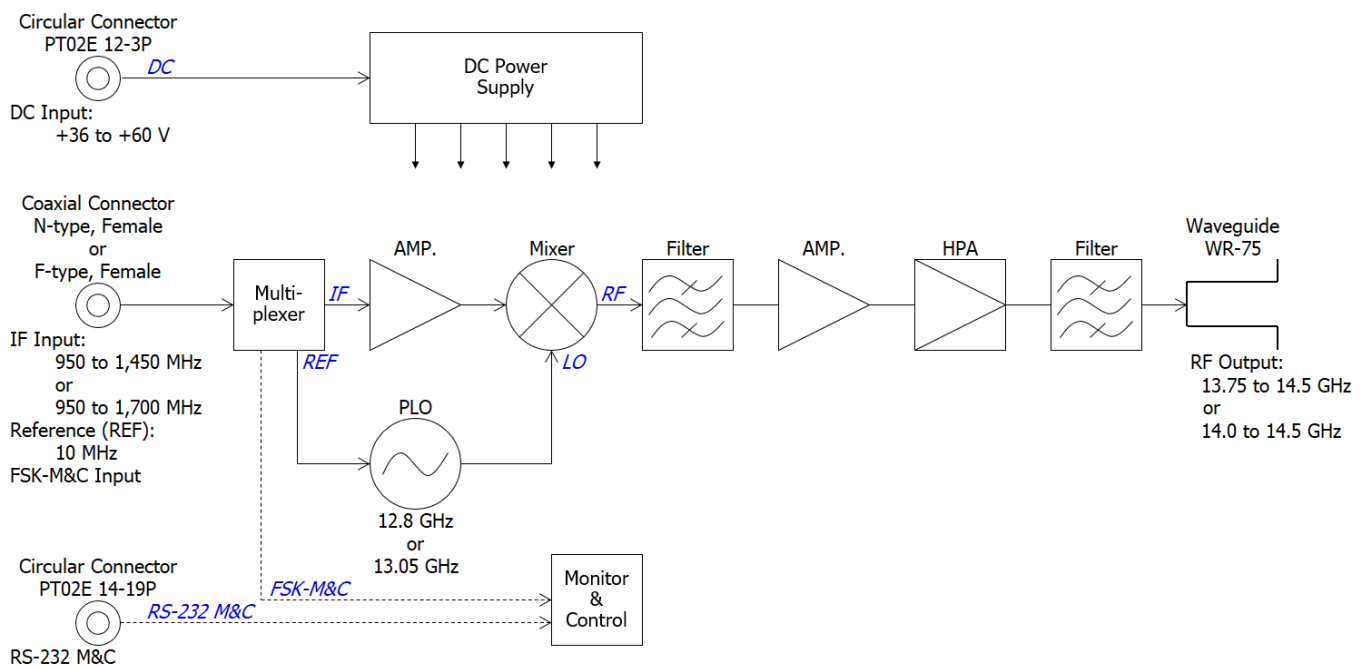
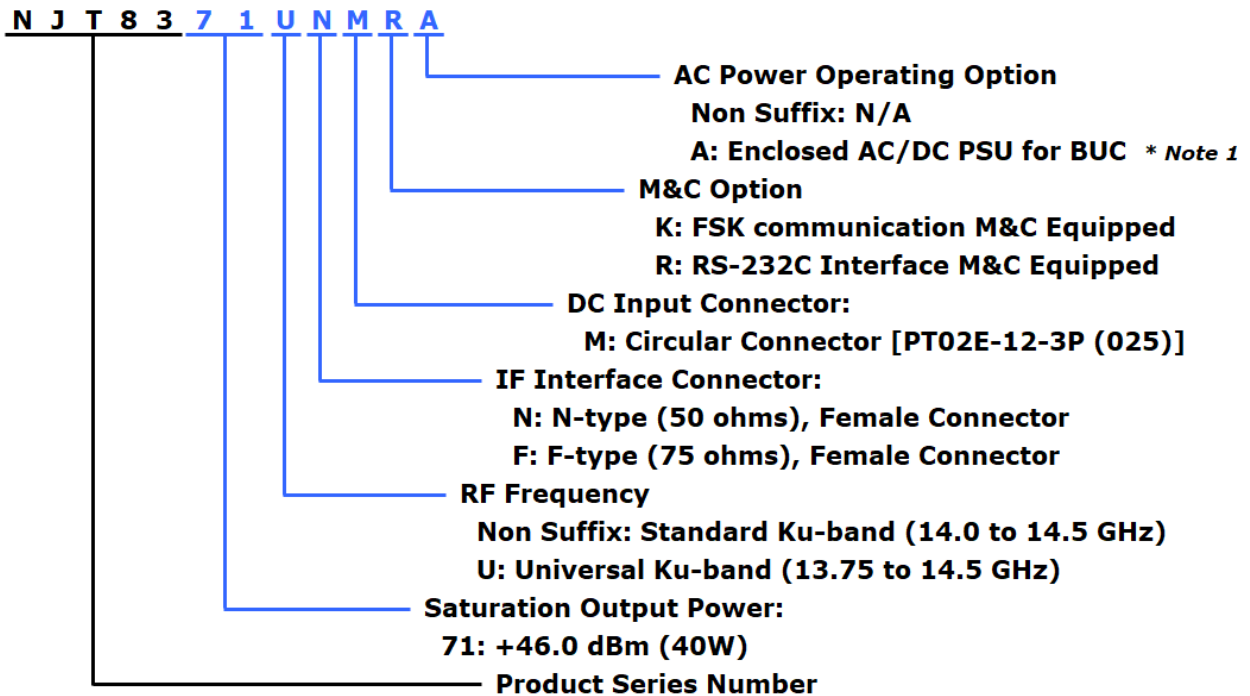

Fig.1 Functional Block Diagram

* Above Specifications are subject to change without notice.

Series Model Number

- Numbering System



- Line-up

Model No.	RF Frequency	Local Frequency	IF Frequency	Output Power	IF Connector	Power Supply	Port for Voltage Input	M&C Option		
NJT8371NMK	14.0 to 14.5 GHz (Standard Ku-band)	13.05 GHz	950 to 1,450 MHz	40W Saturation (+46dBm)	N-type	+36 to +60 V DC Power	Circular Connector	FSK M&C		
NJT8371FMK					F-type					
NJT8371NMKA					N-type	AC Power				
NJT8371FMKA					F-type					
NJT8371NMR					N-type	+36 to +60 V DC Power			RS-232C M&C	
NJT8371FMR					F-type					
NJT8371NMRA	N-type	AC Power								
NJT8371FMRA	F-type									
NJT8371UNMK	13.75 to 14.5 GHz (Universal Ku-band)	12.80 GHz	950 to 1,700 MHz		N-type	+36 to +60 V DC Power		Circular Connector		FSK M&C
NJT8371UFMK					F-type					
NJT8371UNMKA					N-type	AC Power				
NJT8371UFMKA					F-type					
NJT8371UNMR				N-type	+36 to +60 V DC Power	RS-232C M&C				
NJT8371UFMR				F-type						
NJT8371UNMRA	N-type	AC Power								
NJT8371UFMRA	F-type									

*Note1: Additional outdoor 500W AC/DC PSU is enclosed for AC Power Option and DC Power is supplied at Circular connector of BUC from AC/DC PSU via power cable.

* Above Specifications are subject to change without notice.

1. Electrical Specifications

#	Items	Specifications
1.1.	Output RF Frequency Range	
	<Universal Ku-band>	13.75 to 14.5 GHz
	<Standard Ku-band>	14 to 14.5 GHz
1.2.	Input IF Frequency Range	
	<Universal Ku-band>	950 to 1,700 MHz
	<Standard Ku-band>	950 to 1,450 MHz
1.3.	Maximum IF Input Level (without damage)	+13 dBm max.
1.4.	Conversion Type	Single, fixed L.O.
1.5.	L.O. Frequency	
	<Universal Ku-band>	12.8 GHz
	<Standard Ku-band>	13.05 GHz
1.6.	Frequency Sense	Positive
1.7.	Saturation Output Power (Psat)	+46 dBm min. @ +25 °C +45 dBm min. over temperature
1.8.	Linear Gain	72 dB nom., 66 dB min.
1.9.	Gain Variation over frequency @ fixed temperature	
	<Universal Ku-band>	5 dBp-p max. over 750 MHz 2 dBp-p max. over 54 MHz
	<Standard Ku-band>	5 dBp-p max. over 500 MHz 2 dBp-p max. over 54 MHz
1.10.	Gain Stability over temperature @ fixed frequency	4 dBp-p max. 2 dBp-p typ.
1.11.	ACPR	-30 dBc typ., -26 dBc min. @ Pout = +44 dBm
1.12.	Requirement for External Reference	
	[Frequency]	10 MHz (sine-wave)
	[Input Power]	-5 to +5 dBm @ Input port
	[Phase Noise]	-125 dBc/Hz max. @ 100 Hz -135 dBc/Hz max. @ 1 kHz -140 dBc/Hz max. @ 10 kHz
1.13.	L.O. Phase Noise	-60 dBc/Hz max. @ 100 Hz -70 dBc/Hz max. @ 1 kHz -80 dBc/Hz max. @ 10 kHz -90 dBc/Hz max. @ 100 kHz -100 dBc/Hz max. @ 1MHz

* Above Specifications are subject to change without notice.

#	Items	Specifications
1.14.	Spurious @ Pout = +44 dBm <div style="text-align: right; padding-right: 20px;"> [In-band] [Receive band] [Out-of-band] </div>	-50 dBc max. @ RF Frequency -70 dBm max. @ 10.95 to 12.75 GHz -50 dBc max.
1.15.	Receive Band Noise Density <div style="text-align: center; padding: 5px 0;"> <Universal Ku-band> </div>	Tx: 14.0 to 14.5 GHz -156 dBm/Hz max. @10.95 to 12.75 GHz Tx: 13.75 to 14.0 GHz -156 dBm/Hz max. @10.95 to 12.25 GHz -121 dBm/Hz max. @12.25 to 12.75 GHz
	<div style="text-align: center; padding: 5px 0;"> <Standard Ku-band> </div>	Tx: 14.0 to 14.5GHz -156 dBm/Hz max. @ 10.95 to 12.75 GHz
1.16.	Noise Figure	20 dB max.
1.17.	Group Delay over any 54MHz	2.5 nS p-p max.
1.18.	Input Impedance <div style="text-align: center; padding: 5px 0;"> <N-type Model> <F-type Model> </div>	50 ohms nom 75 ohms nom.
1.19.	Input V.S.W.R.	2 : 1 max.
1.20.	Output V.S.W.R.	1.5 : 1 max.
1.21.	Output Load V.S.W.R. for Non Damage	2 : 1 max.
1.22.	DC Power Requirement <div style="text-align: right; padding-right: 20px;"> [Voltage Range] [Power Consumption] </div>	+48 VDC (+36 to +60 VDC) 120 W typ. @ No IF signal 220 W typ. @ Pout=+44dBm 260 W typ., 290 W max. @ Psat
1.23.	Mute	Shut off the HPA in case of L.O. unlocked, no 10 MHz reference signal, or Over temperature. * Note 2
1.24.	LED Indicator	GREEN: L.O. locked RED: L.O. unlocked (or no 10 MHz reference signal)

* Above Specifications are subject to change without notice.

#	Items	Specifications
1.25.	Monitor and Control	
	<p style="text-align: center;"><FSK Communication M&C></p> <p style="text-align: right;">[Interface] [Functions]</p> <p style="text-align: right;">[Performance]</p>	<p>650kHz FSK Signal on IF Connector</p> <p>Monitor: Tx Output Power / Temperature / Tx Status / Alarm (Over temperature * Note 2 / L.O. unlock) / Step Attenuator</p> <p>Control: Transmit On/Off / Step Attenuator</p> <p>Tx Output Power: Detector Range: 15 dB (up to Psat) Reading Accuracy: +/- 1.0 dB</p> <p>Step Attenuator: Attenuator Range: 0 to 31.5 dB Attenuator Step: 0.5 dB</p> <p><i>*Details are mentioned on Appendix of "Specifications Monitor & Control".</i></p>
	<p style="text-align: center;"><RS-232C Interface M&C ></p> <p style="text-align: right;">[Interface] [Functions]</p> <p style="text-align: right;">[Performance]</p>	<p>RS-232C Interface on Circular connector</p> <p>Monitor: Tx Output Power / Temperature / Tx Status / Alarm (Over temperature * Note 1 / L.O. unlock) / Step Attenuator</p> <p>Control: Transmit On/Off / Step Attenuator</p> <p>Tx Output Power: Detector Range: 15 dB (up to Psat) Reading Accuracy: +/- 1.0 dB</p> <p>Step Attenuator: Attenuator Range: 0 to 31.5 dB Attenuator Step: 0.5 dB</p> <p><i>*Details are mentioned on Appendix of "Specifications Monitor & Control".</i></p>

*Note2: Regardless of cooling fan status, the unit will operate until status of over temperature which turn out at internal temperature of around 96 °C, and the Mute and Alarm will function at status of over temperature.

* Above Specifications are subject to change without notice.

2. Mechanical Specifications

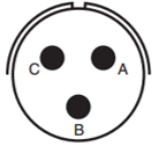
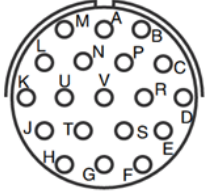
#	Items	Specifications
2.1.	Input Interface <div style="text-align: right; margin-right: 50px;">[IF Connector]</div> <div style="text-align: right; margin-right: 50px;">[Circular Connector]</div>	IF / Ref. / FSK M&C Signal Input: N-type female connector, 50 ohms F-type female connector, 75 ohms DC Input: Circular Connector Part No.: PT02E-12-3P (025) Mating connector: PT06E-12-3S (470) Assignment:  <div style="margin-left: 20px;"> Pin A: DC Input (+) / Prime Pin B: Frame GND Pin C: DC Input (-) / Return </div> M&C Input: Circular Connector * Part No.: PT02E-14-19P (025) Mating connector: PT06E-14-19S (470) Assignment:  <div style="margin-left: 20px;"> Pin A: GND COMMON Pin B: GND COMMON Pin C: N.C. Pin D: N.C. Pin E: N.C. Pin F: GND COMMON Pin G: RS-232C RxD Pin H: RS-232C TxD Pin J: N.C. Pin K: N.C. Pin L: N.C. Pin M: N.C. Pin N: N.C. Pin P: N.C. Pin R: N.C. Pin S: N.C. Pin T: N.C. Pin U: N.C. Pin V: N.C. </div> <i>* This circular connector is available for only RS-232C Interface M&C models.</i>
2.2.	Output Interface	Waveguide, WR-75 (with Grooved)
2.3.	Cooling	Forced-air-cooled

* Above Specifications are subject to change without notice.

#	Items	Specifications
2.4.	Dimension & Housing	230(L) × 150(W) × 100(H) mm [9.07" (L) × 5.91" (W) × 3.94" (H)] without interface connectors and screws
2.5.	Weight	4.2 kg [9.3 lbs]

3. Environmental Specifications

#	Items	Specifications
3.1.	Temperature Range (ambient) [Operating] [Storage]	-40 to +60 °C -40 to +75 °C
3.2.	Humidity	0 to 100 % RH
3.3.	Altitude	15,000 feet (4,572 m)
3.4.	Vibration	5 G [49.03 m/s ²] (3 axis, 50 Hz to 2 kHz) 1 mm p-p (3 axis, 5 to 50 Hz)
3.5.	Shock	30 G [294.20 m/s ²] (3 axis)
3.6.	Waterproof / Dustproof (IP Code Rating)	IP 67
3.7.	Regulations	EU Directive (CE Marking) RE - 2014/53/EU EMC - 2014/30/EU RoHS - 2011/65/EU + (EU)2015/863 Safety: EN62368-1, EN60950-22

* Above Specifications are subject to change without notice.

4. Outline Drawing

4.1. N-type Model, DC Input: MS Connector (Circular Connector), M&C Option: RS-232C Interface M&C

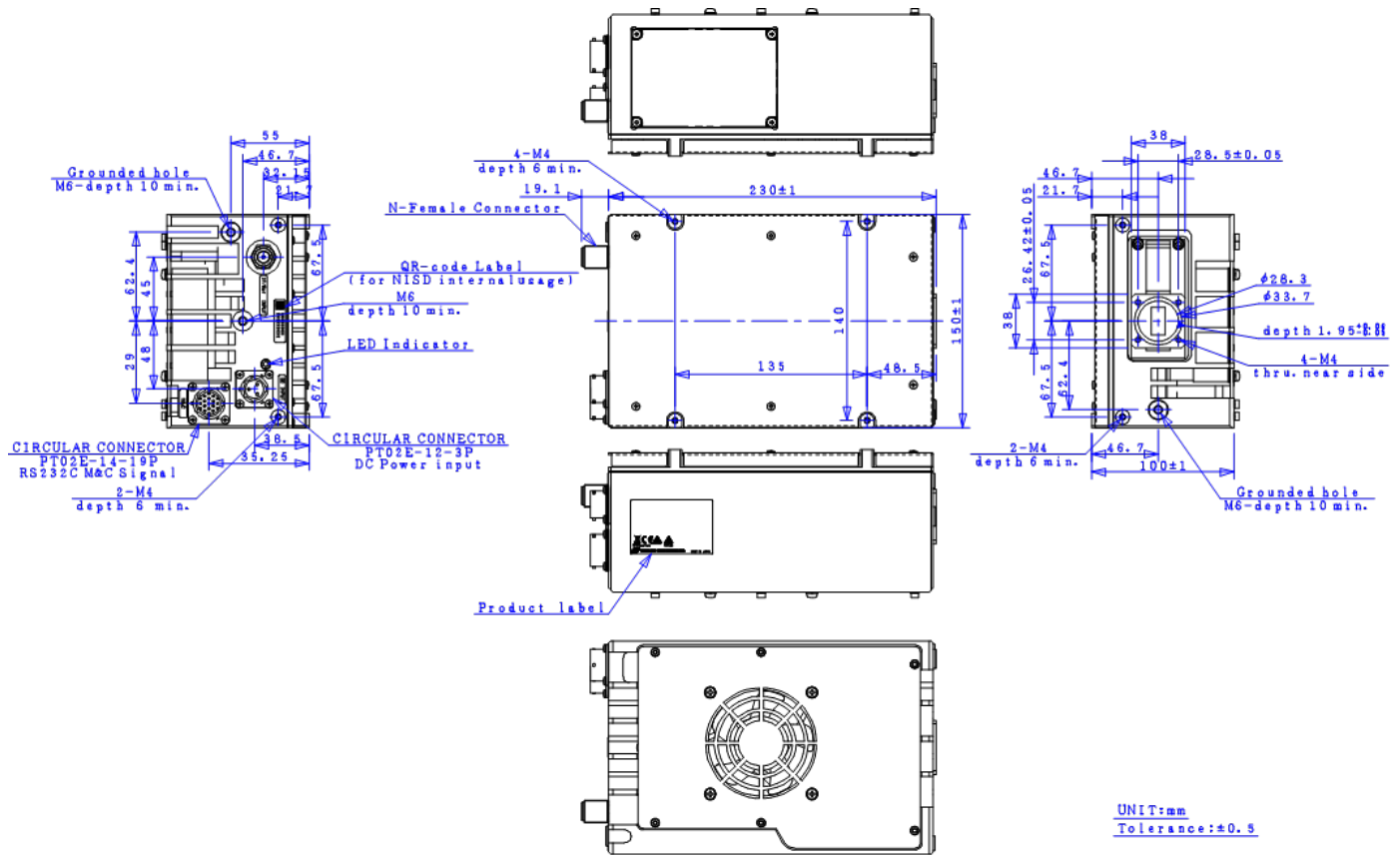

CAUTION

Items	Description
Hot Surface	Whole of body and heat sink is hot when this unit is powered, and even after power is disconnected until it is cooled down. Do not touch hot surface to avoid a burn hazard.
RF Radiation	A radiation hazard exists if this unit is operated with its RF signal output unterminated. Do not operate this unit without a load or termination attached to the RF signal output.
DC Input Connector	Do apply DC voltage on only circular connector. When apply DC voltage on IF connector, this unit may be damaged and/or failure.

* Above Specifications are subject to change without notice.

4.3. N-type Model, DC Input: MS Connector (Circular Connector), M&C Option: FSK Communication M&C

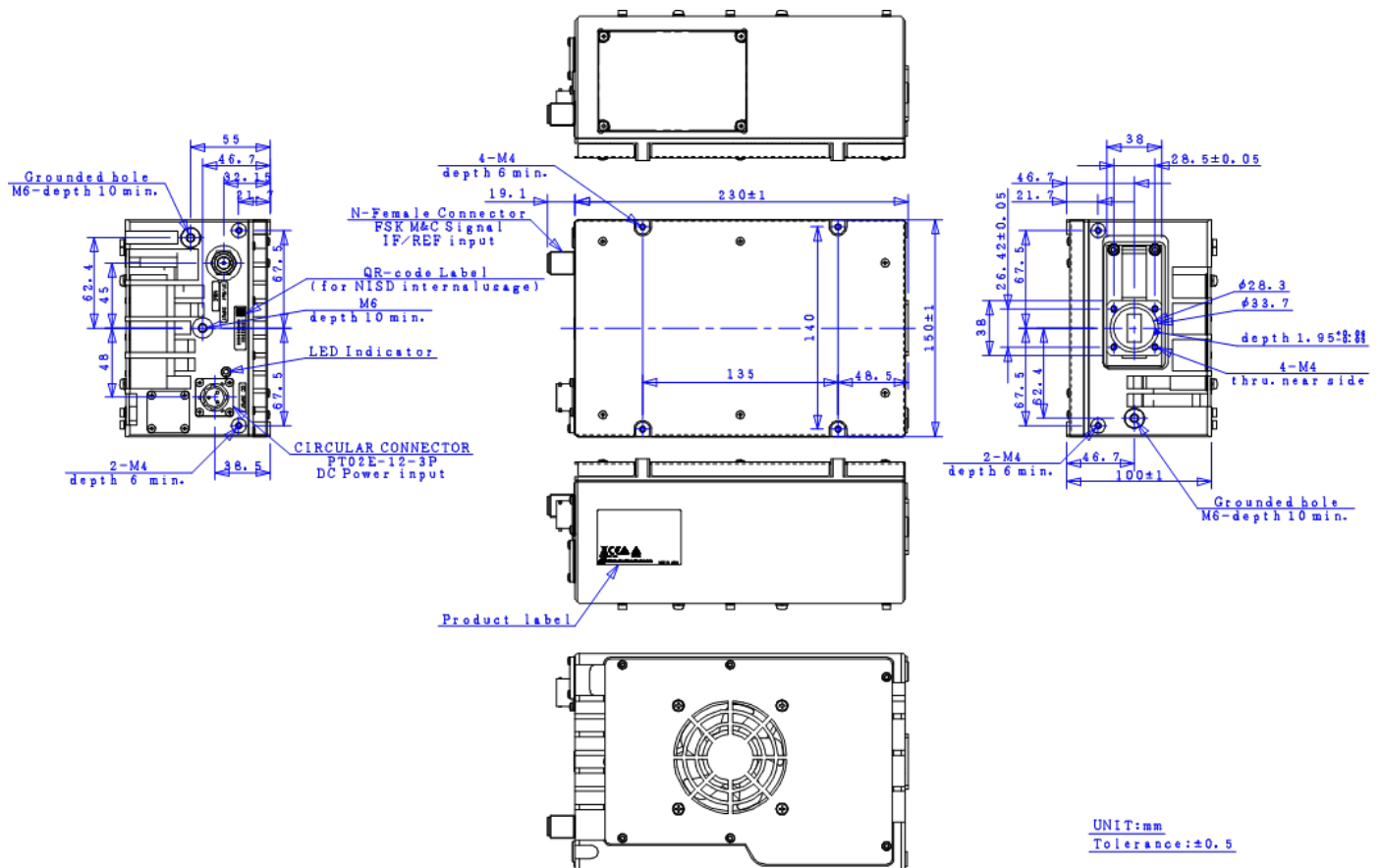

CAUTION

Items	Description
Hot Surface	Whole of body and heat sink is hot when this unit is powered, and even after power is disconnected until it is cooled down. Do not touch hot surface to avoid a burn hazard.
RF Radiation	A radiation hazard exists if this unit is operated with its RF signal output unterminated. Do not operate this unit without a load or termination attached to the RF signal output.
DC Input Connector	Do apply DC voltage on only circular connector. When apply DC voltage on IF connector, this unit may be damaged and/or failure.

* Above Specifications are subject to change without notice.

4.4. F-type Model, DC Input: MS Connector (Circular Connector), M&C Option: FSK Communication M&C

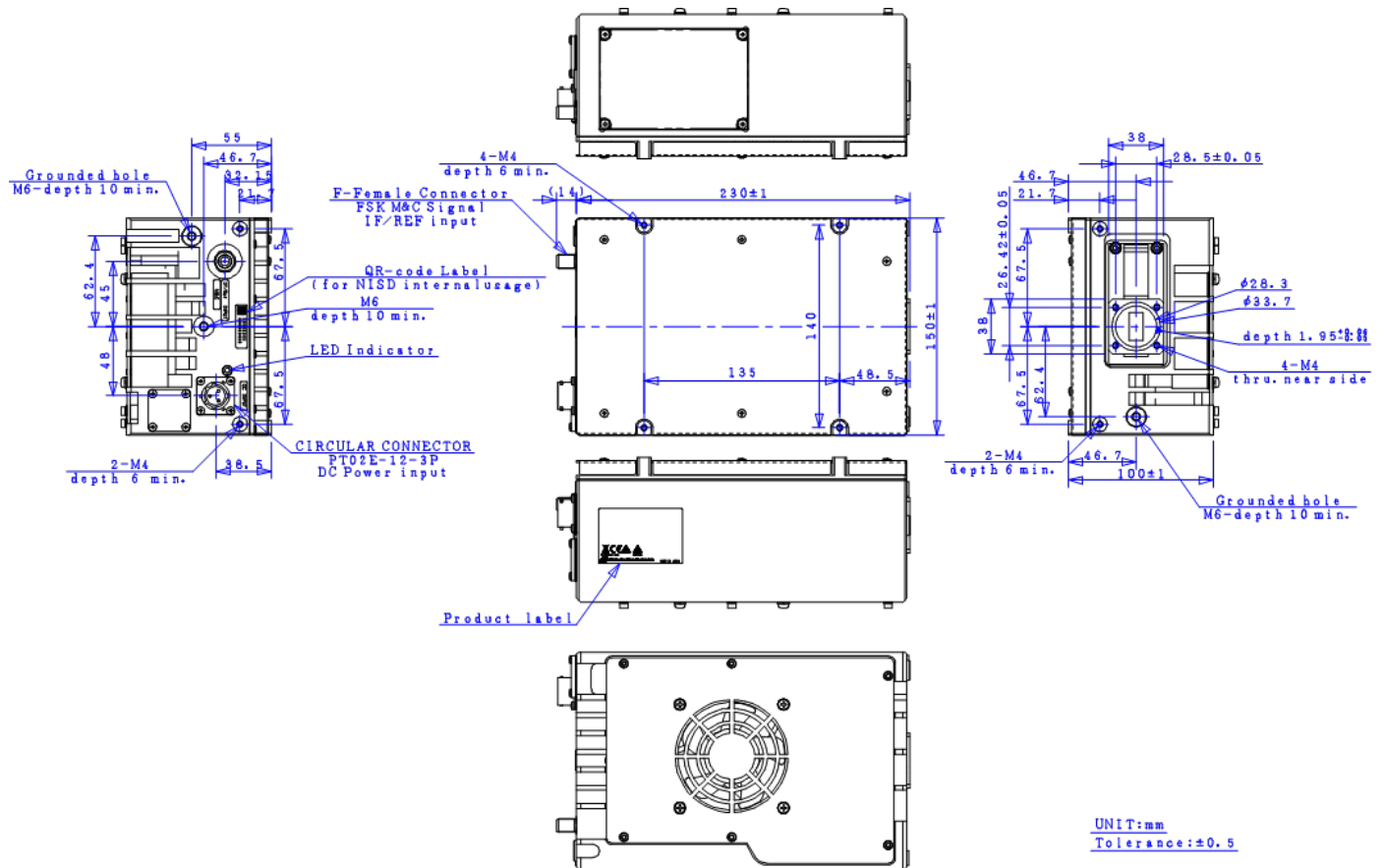

CAUTION

Items	Description
Hot Surface	Whole of body and heat sink is hot when this unit is powered, and even after power is disconnected until it is cooled down. Do not touch hot surface to avoid a burn hazard.
RF Radiation	A radiation hazard exists if this unit is operated with its RF signal output unterminated. Do not operate this unit without a load or termination attached to the RF signal output.
DC Input Connector	Do apply DC voltage on only circular connector. When apply DC voltage on IF connector, this unit may be damaged and/or failure.

* Above Specifications are subject to change without notice.

5. Label

5.1. Label Outline (e.g. NJT8371UNMR)

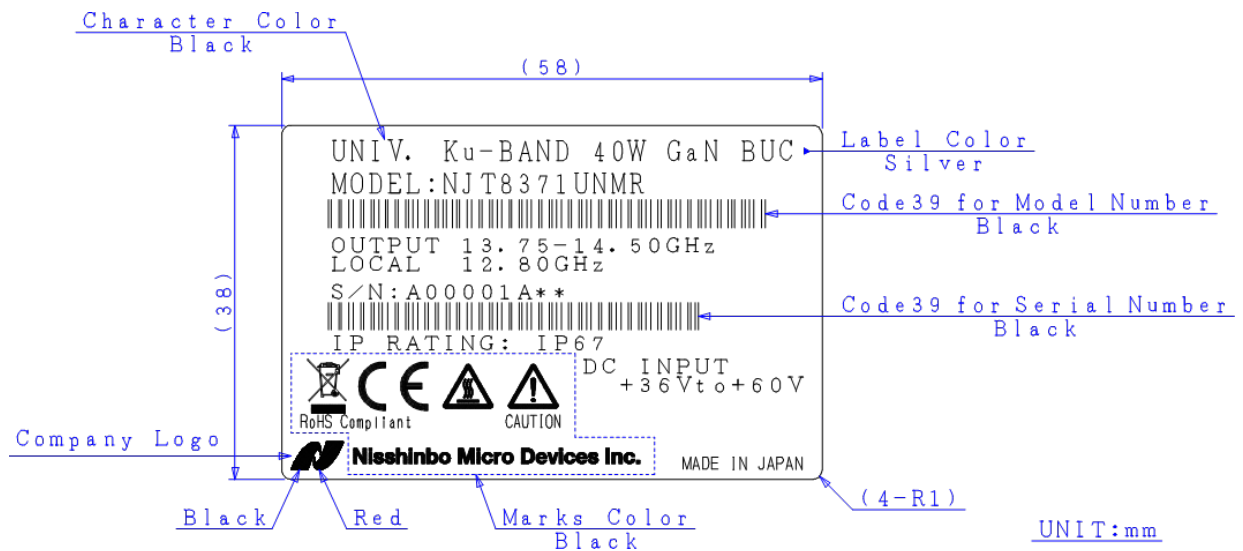

5.2. Definitions

Serial Number (OSSSSSRYM) - ALPHANUMERIC (9 characters)

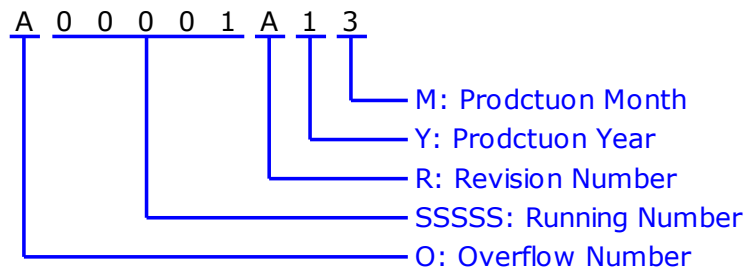

O: Overflow Number - ALPHABET (1 character)

"A" to "T" except "I" and "O", e.g.: A99999 ⇒ B00001

"V" to "Z": Specified Numbers

SSSSS: Running Number - NUMBER (5 digits)

"00001" to "99999"

R: Revision Number - ALPHABET (1 character)

"A" to "Z" except "I", "O", and "U"

Y: Production Year - NUMBER (1 digit)

"0" to "9", Last Digit of Calendar Number

e.g.: 2021:"1", 2022:"2", 2023:"3".....

M: Production Month - ALPHANUMERIC (1 character)

"1" to "9", "X" as October, "Y" as November, "Z" as December

* Above Specifications are subject to change without notice.

6. Package

6.1. Shipping Package

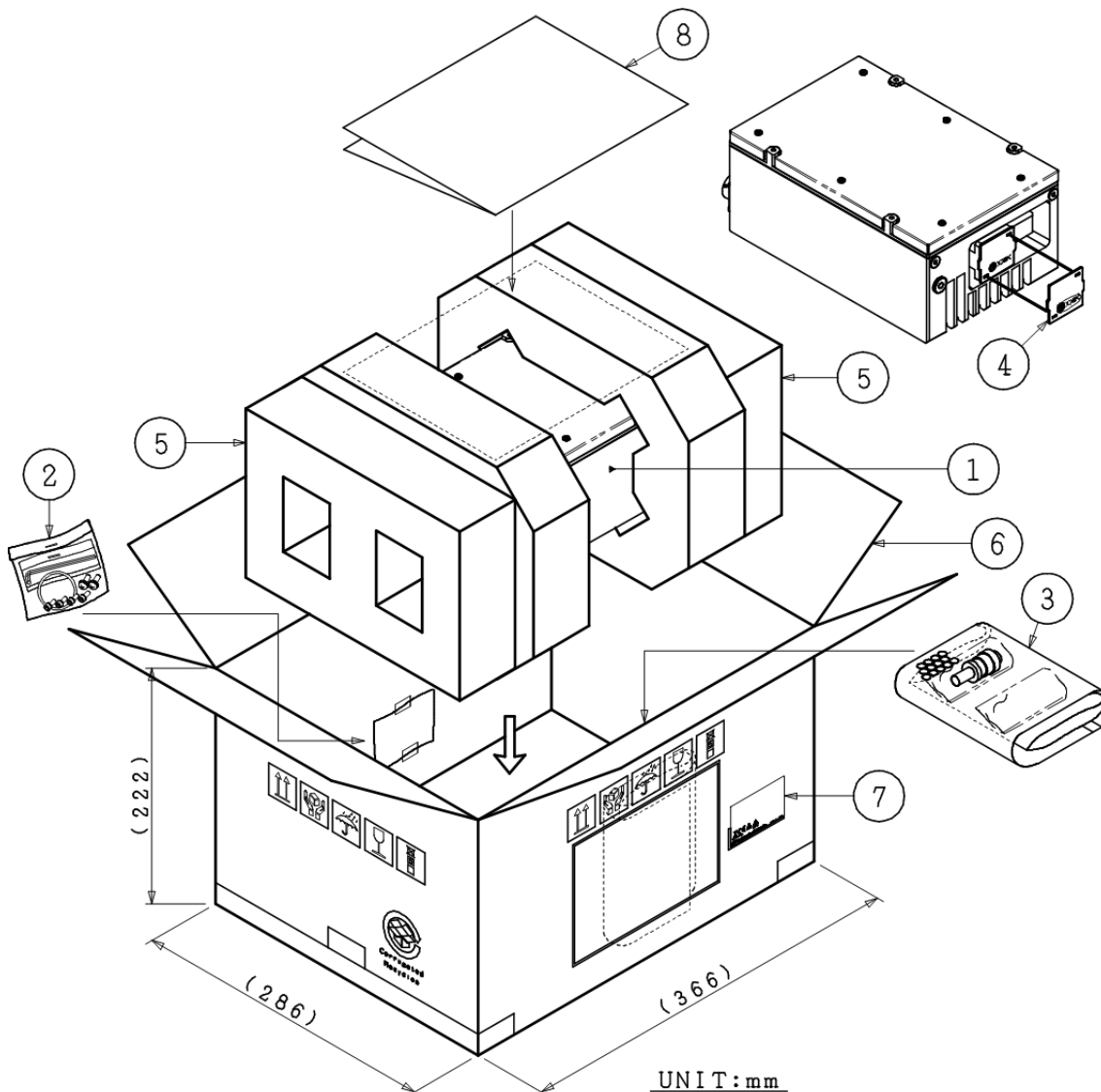

- ①: BUC
 ②: Accessories
 • O-RING
 • Hexagon Socket Head Bolts
 M4×10 4 pieces (SUS, SW and W)
 for Waveguide Flange Holes
 • Hexagon Wrench Keys (M4 Type)
 • Cross Recessed Head Machine Screw
 M6×10 2 pieces (SUS, SW) for Ground Hole
 ③: Accessories
 • MS mating connectors
 ④: Polypropylene Flange Cover
 ⑤: Polyethylene foam for package cushioning
 ⑥: Double-faced corrugated fiberboard
 ⑦: Label
 ⑧: Test Data

* Above Specifications are subject to change without notice.

6.2. Enclosed Accessories

6.2.1. MS Connector (Circular Connector) DC Input Model, M&C Option: RS-232C Interface M&C

- O-ring, Qty (1), for waveguide flange
- Wrench Key, Qty (1), M4, Hexagon
- Bolts, Qty (4), M4 x 10, Hexagon socket head with spring washer and flat washer, SUS, for waveguide flange
- Screws, Qty (2), M6 x 10, Phillips head with spring washer and flat washer, SUS, for grounded hole
- Connector, Qty (1), MS Mating connector: PT06E-12-3S (470)
- Connector, Qty (1), MS Mating connector: PT06E-14-19S (470)

6.2.2. MS Connector (Circular Connector) DC Input Model, M&C Option: FSK Communication M&C

- O-ring, Qty (1), for waveguide flange
- Wrench Key, Qty (1), M4, Hexagon
- Bolts, Qty (4), M4 x 10, Hexagon socket head with spring washer and flat washer, SUS, for waveguide flange
- Screws, Qty (2), M6 x 10, Phillips head with spring washer and flat washer, SUS, for grounded hole
- Connector, Qty (1), MS Mating connector: PT06E-12-3S (470)

* Above Specifications are subject to change without notice.

7. Reference Performance

7.1. Output Power/Gain Compression vs. Input Power

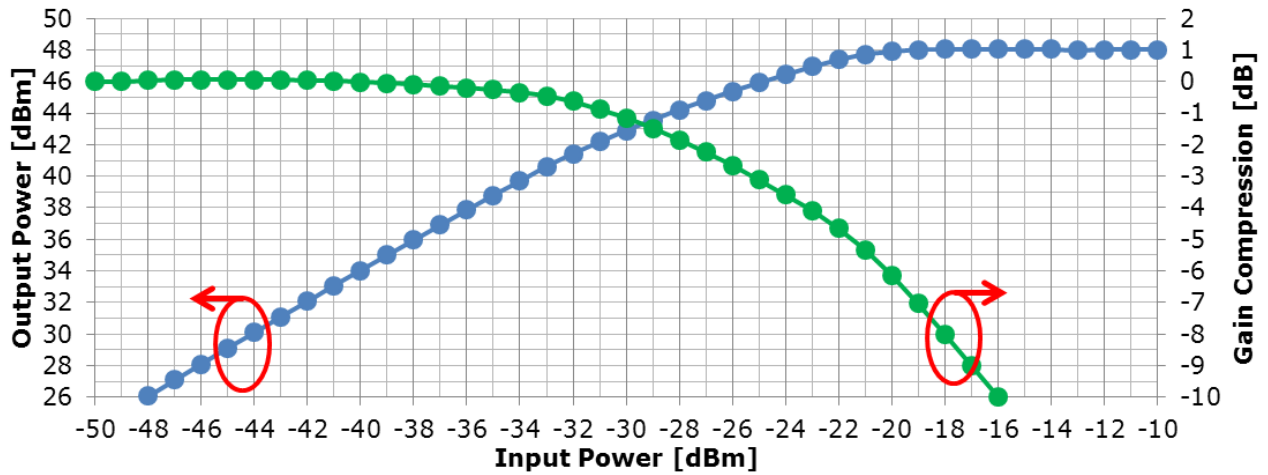

7.2. Output Power/Power Consumption vs. Input Power

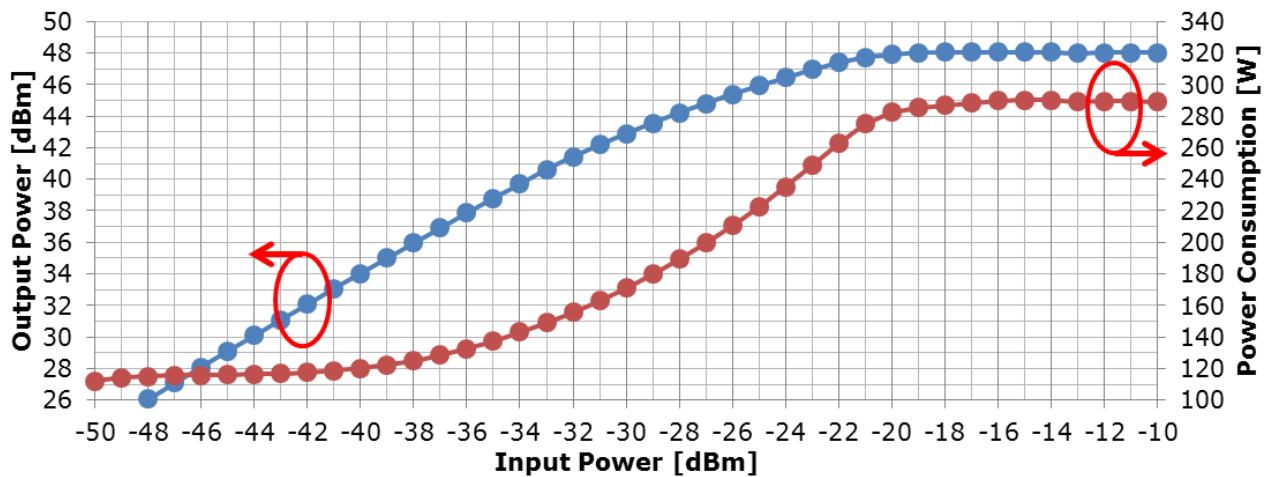

* Above Specifications are subject to change without notice.

8. Handling Precautions

8.1. DANGER



This statement indicates an imminently hazardous situation which, if not avoided, will result in death or serious injury.

Items	Description
Input Voltage	Only input a DC voltage within the range indicated in specifications. <u>Do</u> operate with the input voltage range between +36 and +60 V DC power. When applying higher voltage than specifications (+60 V as maximum voltage in DC power requirement), it will not only cause this unit failure, but it may also result in <u>electric shock</u> and <u>fire</u> .
Disassembling	<u>Do not</u> disassemble the unit. Disassembling will not only cause this unit failure, but it may also result in <u>electric shock</u> .

8.2. WARNING



This statement indicates a potentially hazardous situation which, if not avoided, could result in death or serious injury.

Items	Description
RF Radiation	A radiation hazard exists if this unit is operated with its RF signal output unterminated. <u>Do not</u> operate this unit without a load or termination attached to the RF signal output.
Hot Surface	Whole of body and heat sink is hot when this unit is powered, and even after power is disconnected until it is cooled down. <u>Do not</u> touch hot surface to avoid a burn hazard.

* Above Specifications are subject to change without notice.

8.3. CAUTION



This statement indicates a potentially hazardous situation which, if not avoided, could result in minor or moderate injury. The statement may also be used to indicate other unsafe practices or risks of property damage.

Items	Description
Fan Rotation	<p><u>Do not</u> insert finger into the fan in every case and time to avoid injury also <u>do not</u> insert any objects into the fan.</p> <p>Keep any objects away from the fan. Incorrect usage may cause injury to self or others.</p>
Disposal	<p>This unit contains gallium arsenide (GaAs), classified as a harmful substance. To avoid danger, <u>do not</u> incinerate, crush, or chemically treat the unit in such a way that gases or dust are released.</p> <p>When disposing the unit, comply with all applicable laws and regulations and <u>do not</u> treat it as general industrial waste or household waste.</p>

8.4. NOTE



This statement is used to notify of installation, operation, or maintenance information that is important, but not hazard-related.

Items	Description
Mounting	<p><u>Do not</u> block fins of this unit to keep the heat dissipation performance.</p> <p>Normally the unit should be mounted with fan face down.</p>
Grounding	<p>To reduce the risk of damage or broken by lightning surge, the unit should be grounded by connecting the ground wire.</p>
Torque Management	<p><u>Do not</u> tighten with excessive torque when attaching screws/bolts and connectors.</p> <p>The following value as tighten torque is recommended.</p> <ul style="list-style-type: none"> ■ Screws/Bolts - M4: 1.52 ± 0.152 N·m M6: 1.58 ± 0.158 N·m ■ IF Connector (N-type / F-type): 0.68 to 1.13 N·m (3.92 N·m as maximum allowable torque. When over this torque, connector may be damaged.)
Weatherproof	<p>The unit mounted in outdoor should be conducted with adequately weatherproof procedure.</p> <p>Do seal all of cable connection points from the connector to the cable sheath by usage of self-amalgamating tape.</p> <p>Ensure the waveguide connection is properly assembled with the enclosed o-ring gasket as accessories. The o-ring gasket is full-type and it is assumed to connect the unit to a flat waveguide flange.</p>

* Above Specifications are subject to change without notice.

Items	Description
Input Voltage	<u>Do</u> operate with the input voltage range between +36 and +60 V DC power. Avoid applying more than the maximum voltage in this range (including ripple voltage) under any conditions.
Input IF Signal Power	<u>Do not</u> supply the input IF signal over the maximum level (+13 dBm), which is indicated on the product label.
Input 10MHz Signal Power	The 10 MHz reference signal should be supplied with the range between -5 and +5 dBm with sine-wave for correctly operation. <u>Do not</u> supply the signal level of more than +13 dBm, which is indicated on the product label.
High Temperature Operation	It may cause damage and/or degradation of reliability / lifetime to operate the unit in a condition where the ambient temperature exceeds the maximum value, <u>+60 °C</u> , at operating temperature described in the specifications.
Vibration / Shock	When vibration and/or shock impact exceeding the conditions described in the specifications is applied, internal parts may be damaged.
Fan Maintenance	The fan has its lifetime. The fan is to be replaced with a new one at appropriate interval. The recommendation interval of replacement is five(5) years.
Warranty	The unit is covered by a warranty for one(1) year following delivery unless otherwise stipulated in the contract or delivery conditions. Repairs may be possible under payment of charge even for the unit whose warranty period has expired. Opening, removing, disassembling and modifying any parts and components (including the product label, sealing tape and screws) without fan equipment will immediately void the warranty. In any case, the unit of invalid warranty cannot be repaired.

* Above Specifications are subject to change without notice.

9. Instructions Manual

9.1. Descriptions

This section describes the information of connectors and etc.

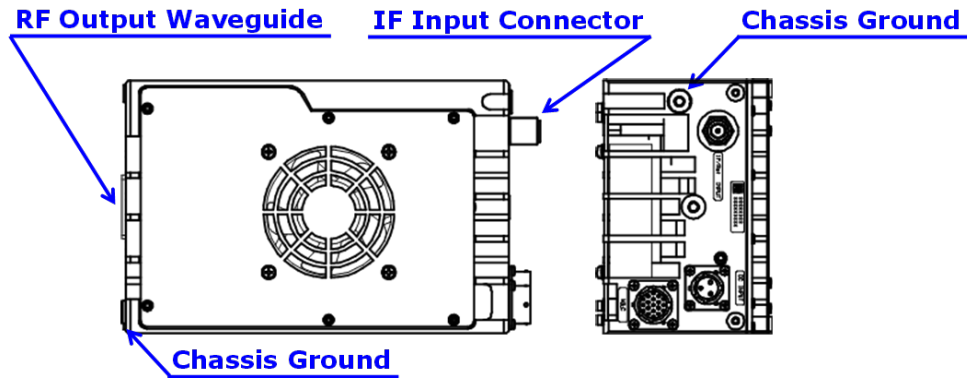

Items	Description	Purpose
RF Output Waveguide	Waveguide: WR-75 Flange: Square Cover Grooved (Equivalent to PBR 120)	The BUC transmits an RF signal of Ku-band (13.75 to 14.5 GHz, or 14 to 14.5 GHz) output with up to 40W (+46 dBm) linear as output power @ 1 dB G.C.P. (P1dB) via this waveguide.
Chassis Ground	M6 Screw	Common chassis ground / frame ground.
IF Input Connector	F-type Female Coaxial Connector, 75 Ohms OR N-type Female Coaxial Connector, 50 Ohms	The BUC inputs an IF signal of L-band (950 to 1,450 MHz, or 950 to 1,700 MHz), and requires to supply +36 to +60 V DC power and a 10 MHz reference signal via this connector.

9.2. Connection and Installation

This section describes basic installation for the BUC.

9.2.1. Mounting Configuration

The Unit can be mounted with OMT or the waveguide filter of the satellite antenna.

When mounting with the OMT or the waveguide filter, the following steps should be complied:

* Above Specifications are subject to change without notice.

Step 1: Verify that the groove on the waveguide flange for a gasket is clean.

The enclosed o-ring gasket as accessories is full-type and it is assumed to connect the BUC to a flat waveguide flange (non-grooved waveguide flange). Insert the o-ring gasket the groove as shown in the figure on the right. The o-ring gasket and flange groove dimensions is customized and optimized for this BUC; therefore any other o-ring gasket than the enclosed accessory is not permitted for using.

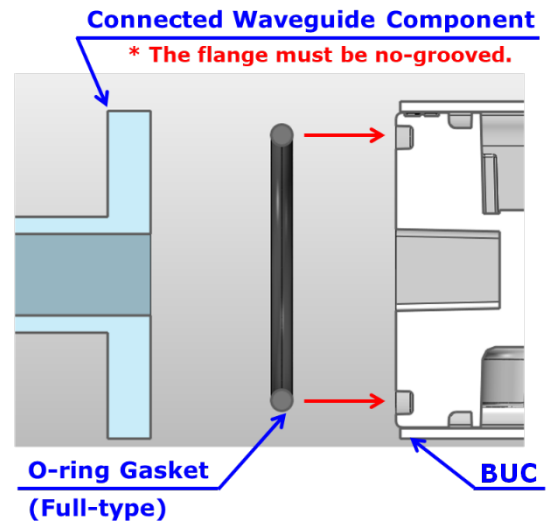

Step 2: Secure the OMT or the filter to the LNB by tightening the enclosed Phillips head screws (M4 x 10 mm) with 1.52 to 0.152 N·m torque as shown in the figure below, when the thickness of the flange of the OMT or filter is assumed to be 3 to 5 mm. The enclosed washers as accessory must be inserted to bolts before tightening bolts.

When the thickness is exceed 5 mm, the appropriate length screws or bolts based should be prepared on the table on the right.

Flange Thickness of OMT/Filter	Screw Length
3 to 5 mm	10 mm
5 to 7 mm	12 mm
7 to 9 mm	14 mm
9 to 11 mm	16 mm

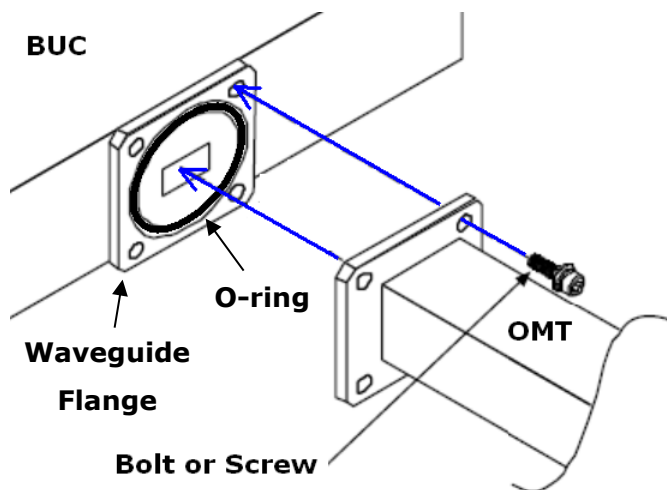

! NOTE

- ✓ The BUC must be adequately weatherproofed to place in outdoor.
Ensure that the waveguide joint is properly sealed with the enclosed o-ring gasket.

* Above Specifications are subject to change without notice.

9.2.2. Connecting Coaxial Cable

The BUC is connected the modem with a coaxial cable, and requires to supply +12 to +30 V DC power and a 10 MHz reference signal from the modem.

The connection of coaxial cable should be complied with the following steps:

Step 1: Connect the coaxial cable with the N or F-type male connectors to the coaxial connector equipped with the BUC which is shown in the figure on the right below under 0.68 to 1.13 N·m tighten torque.

Step 2: Use self-amalgamating tape to seal connector and cable entry points from the connector to the cable sheath.

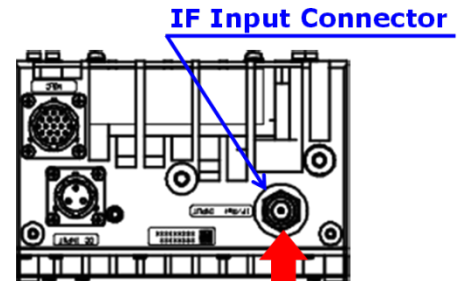

Connect the coaxial cable, and supplied the DC Power and 10MHz reference signal from modem.

Do not power on the modem before finishing all of steps of Connecting Coaxial Cable.

! NOTE

- ✓ The BUC must be adequately weatherproofed to place in outdoor.
Do seal all of cable connection points from the connector to the cable sheath by usage of self-amalgamating tape.

9.2.3. Connecting Ground Wire for Chassis Ground

The BUC can be had the chassis ground of the other equipment (e.g. modem) in common.

Connecting wire for common chassis ground from the chassis ground of the other equipment should be complied with the following step:

Tools Required: #2 Phillips screwdriver

Step: Connect the ground wire from earth ground or chassis ground of other equipment to the chassis ground with M6 x 10 mm Philips pan head screw under 1.52 ± 0.152 N·m tighten torque.

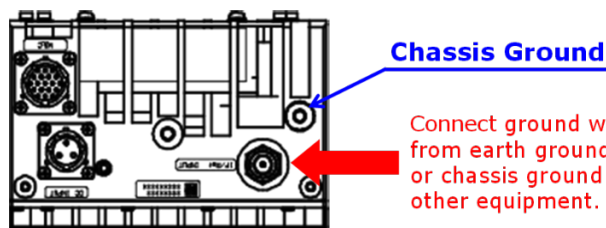

Connect ground wire from earth ground or chassis ground of other equipment.

! NOTE

- ✓ To reduce the risk of damage or broken by lightning surge, the unit should be grounded by connecting the ground wire.

* Above Specifications are subject to change without notice.

9.2.4. Start-up

Start-up will be immediately performed with the following step:

Step: Power on the modem and supply the DC voltage and 10 MHz reference from modem.



DANGER

- ✓ Only input a DC voltage within the range indicated in specifications.
Do operate with the input voltage range between +36 and +60 V DC power.
When applying higher voltage than specifications (+60 V as maximum voltage in DC power requirement), it will not only cause this unit failure, but it may also result in electric shock and fire.



NOTE

- ✓ The 10 MHz reference signal should be supplied with the range between -5 and +5 dBm with sine-wave for correctly operation.
Do not supply the signal level of more than +13 dBm.
- ✓ Do not power on the modem before finishing all of steps of Connection and Installation.

* Above Specifications are subject to change without notice.

Appendix Outdoor 500W AC/DC Power Supply Unit

This appendix mentions about Outdoor 500W AC/DC Power Supply Unit(PSU) for AC power operation option.

Outdoor 500W AC/DC Power Supply Unit(PSU)

Model No. NJZ1295

Input AC Voltage Range: 100 to 240 V

Output DC Power: 500 W

Output DC Voltage: +51 VDC

* Above Specifications are subject to change without notice.

Appendix Outdoor 500W AC/DC Power Supply Unit

1. Overview

The features of Outdoor 500W AC/DC Power Supply Unit (PSU) are to provide the stable +51V DC power to operate High Power BUCs, even if power supply of the equipment is not capable enough to operate the BUC.

This unit employs the aluminum housing with corrosion-proof treatment on the surface and has air-sealing structure in order to use perfectly as the outdoor unit.

In addition, the outdoor 500W AC/DC PSU complies with EU DIRECTIVE.

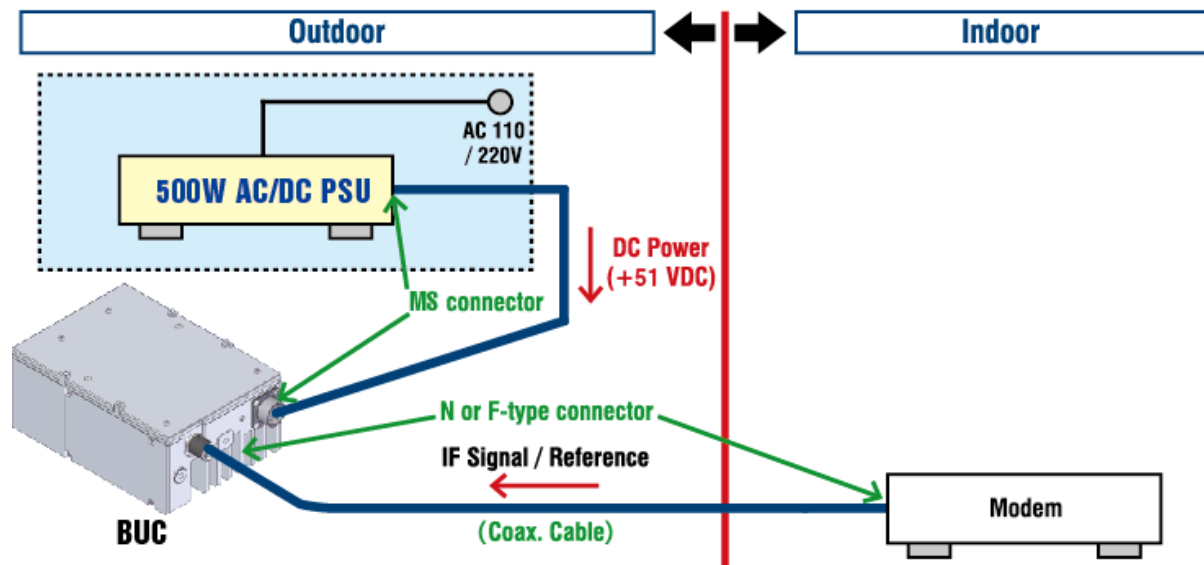

* Above Specifications are subject to change without notice.

Appendix Outdoor 500W AC/DC Power Supply Unit

2. Electrical Specifications

#	Items	Specifications
2.1.	Input AC Voltage Range [Rated Range] [Absolute Maximum Rating]	100 to 240 VAC 90 to 264 VAC
2.2.	Input AC Frequency Range	50/60 Hz
2.3.	Input AC Current	6 A max. @ 110V Input 3 A max. @ 230V Input
2.4.	Output Voltage	+51 VDC +/- 3 V
2.5.	Output Current	9.8 A max.(output:+51Vdc , 500W Load) @110V/230V Input * Note 3
2.6.	Maximum Output Power	500 W at 110V/230V Input * Note 3
2.7.	Efficiency	85 % typ. @ 110V Input & 500W Load 88 % typ. @ 230V Input & 500W Load * Note 4
2.8.	Power Factor	0.96 typ. @ 110V Input & 500W Load 0.93 typ. @ 230V Input & 500W Load * Note 4

*Note3: The detail refers to a graph of the output power derating curve in below.

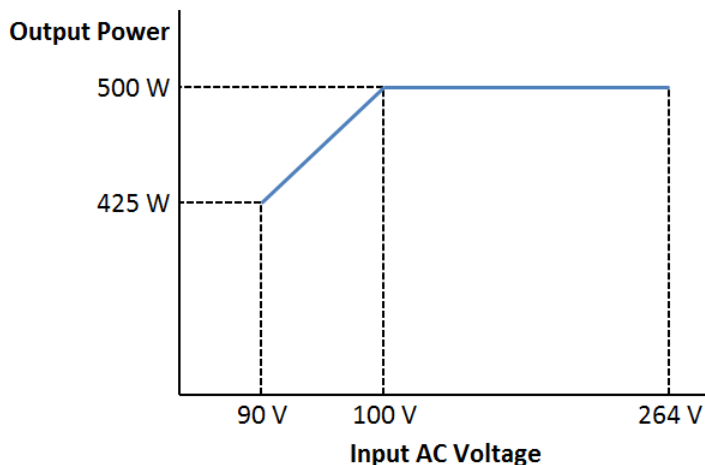

*Note4: The condition is 110 and 230 VAC as AC voltage input and no FAN cycling.

* Above Specifications are subject to change without notice.

Appendix Outdoor 500W AC/DC Power Supply Unit

3. Mechanical Specifications

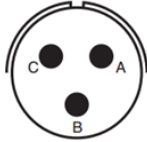
#	Items	Specifications
3.1.	Input Interface [AC Input]	AC Connector: GTS030-16-10P (025) Mating Connector: GTS06CF-16-10S (025) (Amphenol GT connector) Assignment:  <ul style="list-style-type: none"> Pin A: AC input (Live) Pin B: Frame Ground (GND) Pin C: AC input (Neutral)
3.2.	Output Interface [DC & Option Output]	Circular Connector: PT02E-12-3P (025) Mating Connector: PT06E-12-3S (470) (Amphenol PT connector) Assignment:  <ul style="list-style-type: none"> Pin A: DC Output (+) / Prime Pin B: Frame GND Pin C: DC Output (-) / Return
3.3.	Dimension & Housing	250 (L) x 191 (W) x 118.1 (H) mm [9.84" (L) x 7.52" (W) x 4.65" (H)] without interface connectors and screws
3.4.	Weight	5.0 kg [11 lbs.]
3.5.	Surface Finish [Protective & Conformal Coating] [Finish Paint]	Trivalent Chromate Treatment Polyurethane Paint, Ivory Color
3.6.	Cooling	Forced-air-cooled

* Above Specifications are subject to change without notice.

Appendix Outdoor 500W AC/DC Power Supply Unit

4. Environmental Specifications

#	Items	Specifications
4.1.	Temperature Range (ambient) [Operating] [Storage]	-40 to +60 °C -40 to +75 °C
4.2.	Humidity	0 to 100 % Rh
4.3.	Altitude	4,572 m [15,000 ft]
4.4.	Vibration	3.2 G [31.3 m/s ²] (3 axis, 10 Hz to 1 kHz) 1 mm p-p (3 axis, 5 to 50 Hz)
4.5.	Shock	30 G [294.2 m/s ²] (3 axis)
4.6.	Waterproof / Dustproof (IP Code Rating)	IP67 ^{*Note 5}
4.7.	Regulations	EU Directive (CE Marking) EMC - 2014/30/EU Low Voltage - 2014/35/EU RoHS - 2011/65/EU + (EU)2015/863
4.8.	Standard [Safety] [EMC]	IEC60950-1:2005+A1:2009+A2:2013 EN60950-1:2006+A11:2009+A1:2011+A12:2012+A2:2013 *Category and group : Overvoltage Category :II Pollution Degree :1 Material Group :IIIab EN61000-3-2 (Harmonic Current Emission Test) EN61000-3-3 (Voltage Fluctuations and Flicker Test) EN61000-4-2 (ESD Test) EN61000-4-3 (Radio-Frequency Electromagnetic Field Test) EN61000-4-4 (Electrical Fast Transient/Burst Test) EN61000-4-5 (Surge Test) EN61000-4-6(Conducted Disturbance Radio-Frequency Test) EN61000-4-8 (Power Frequency Magnetic Field Test) EN61000-4-11 (Voltage Dips and Interruptions Test) EN55022-B (Disturbance Voltage Test)
4.9.	MTBF (by Method of Parts Count Reliability Prediction)	100,000 hours and more at +60 °C as Design Condition

*Note5: Conditioned on connection with all of enclosed mating connectors.

* Above Specifications are subject to change without notice.

Appendix Outdoor 500W AC/DC Power Supply Unit

5. Accessories

- AC Connector (Plug socket), Qty (1), Mating connector: GTS06CF-16-10S (025)
- MS Connector (Circular Connector) (Plug socket), Qty (1), Mating connector: PT06E-12-3S (470)

* Above Specifications are subject to change without notice.

Appendix Outdoor 500W AC/DC Power Supply Unit

6. Outline Drawing

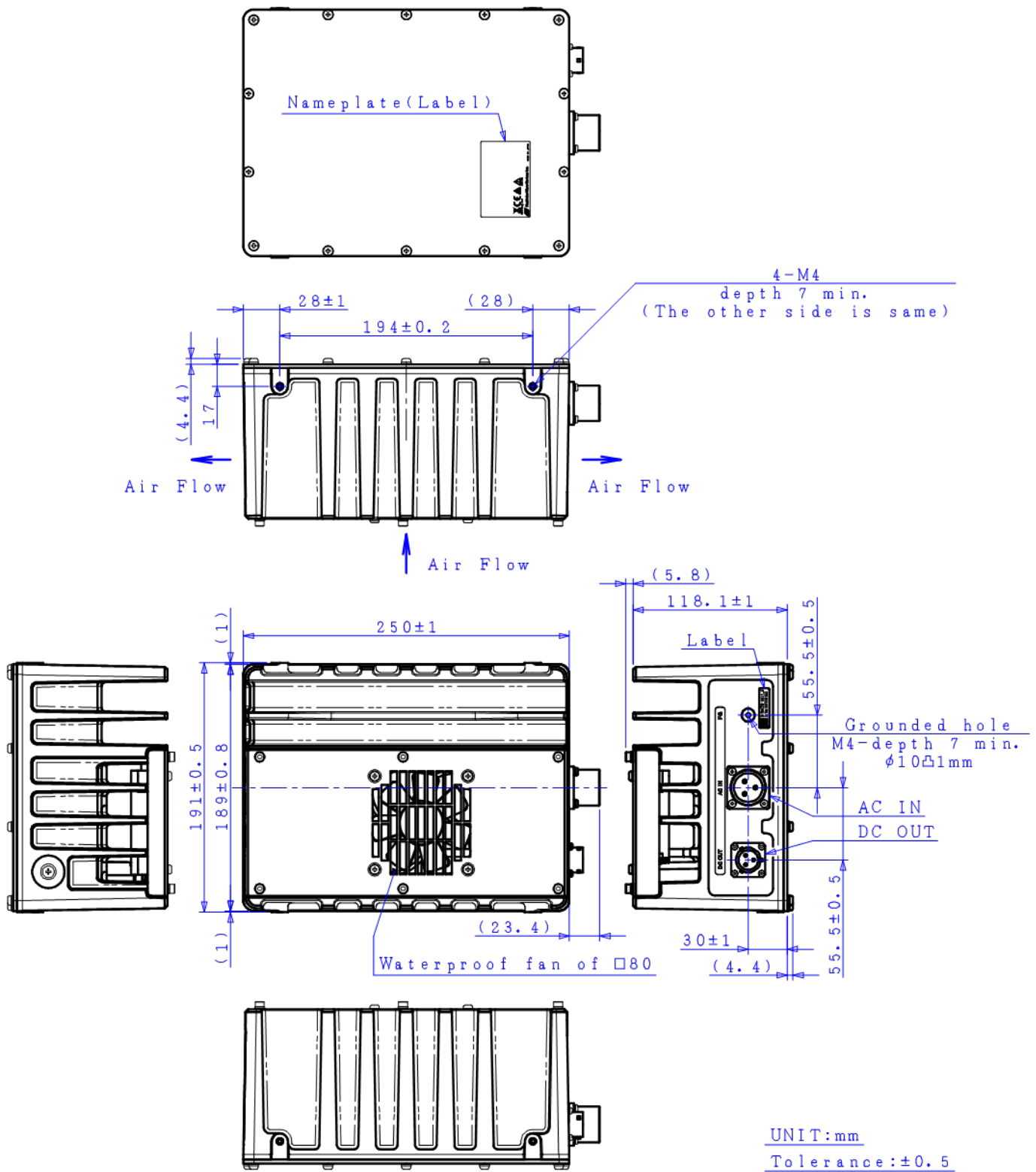

* Above Specifications are subject to change without notice.

Appendix Outdoor 500W AC/DC Power Supply Unit

7. Label

7.1. Label Outline

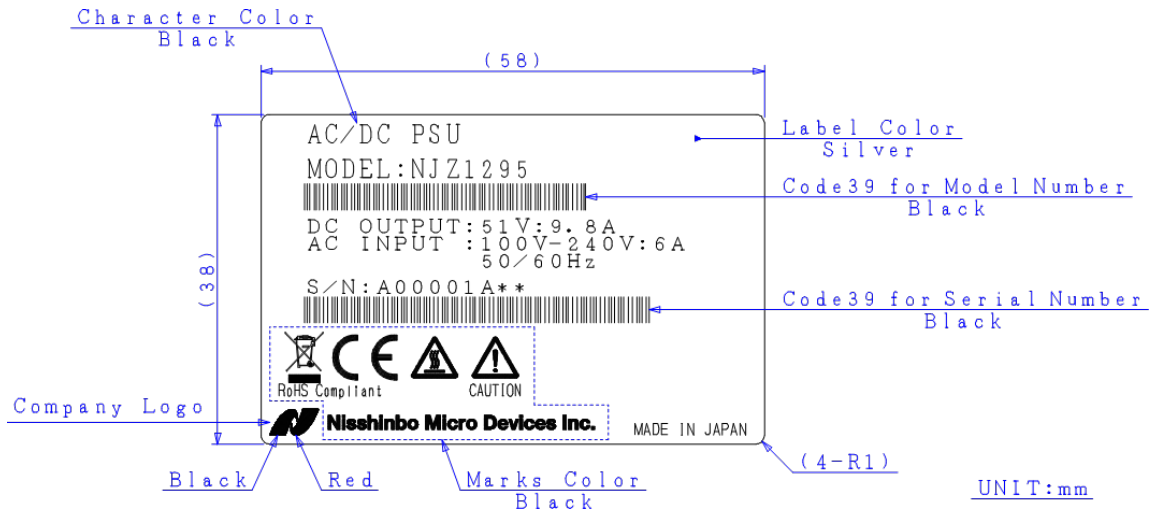

7.2. Definitions

Serial Number (OSSSSSRYM) - ALPHANUMERIC (9 characters)

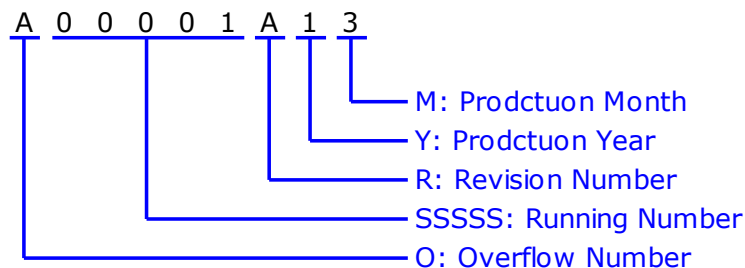

O: Overflow Number - ALPHABET (1 character)

"A" to "T" except "I" and "O", e.g.: A99999 ⇒ B00001

"V" to "Z": Specified Numbers

SSSS: Running Number - NUMBER (5 digits)

"00001" to "99999"

R: Revision Number - ALPHABET (1 character)

"A" to "Z" except "I", "O", and "U"

Y: Production Year - NUMBER (1 digit)

"0" to "9", Last Digit of Calendar Number

e.g.: 2021:"1", 2022:"2", 2023:"3".....

M: Production Month - ALPHANUMERIC (1 character)

"1" to "9", "X" as October, "Y" as November, "Z" as December

* Above Specifications are subject to change without notice.

Appendix Outdoor 500W AC/DC Power Supply Unit

8. Package

8.1. Individual Package of PSU

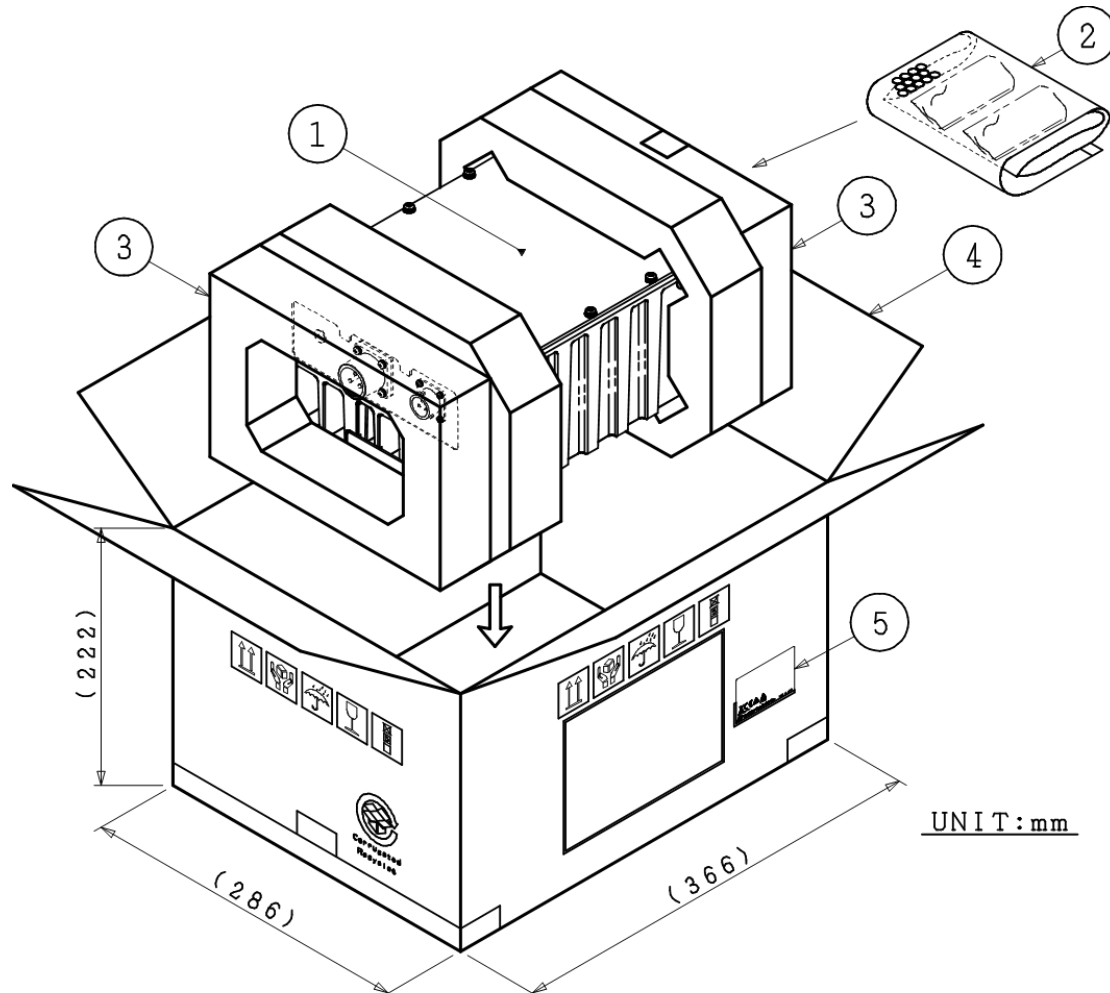

UNIT: mm

- ①: AC/DC PSU
- ②: Accessories
 - AC mating connector
GTS06CF16-10S(025)
 - MS mating connector
PT06E-12-3S(470)
- ③: Polyethylene foam for package cushioning
- ④: Double-faced corrugated fiberboard
- ⑤: Label

* Above Specifications are subject to change without notice.

Appendix Outdoor 500W AC/DC Power Supply Unit

8.2. Shipment Package (BUC and PSU)

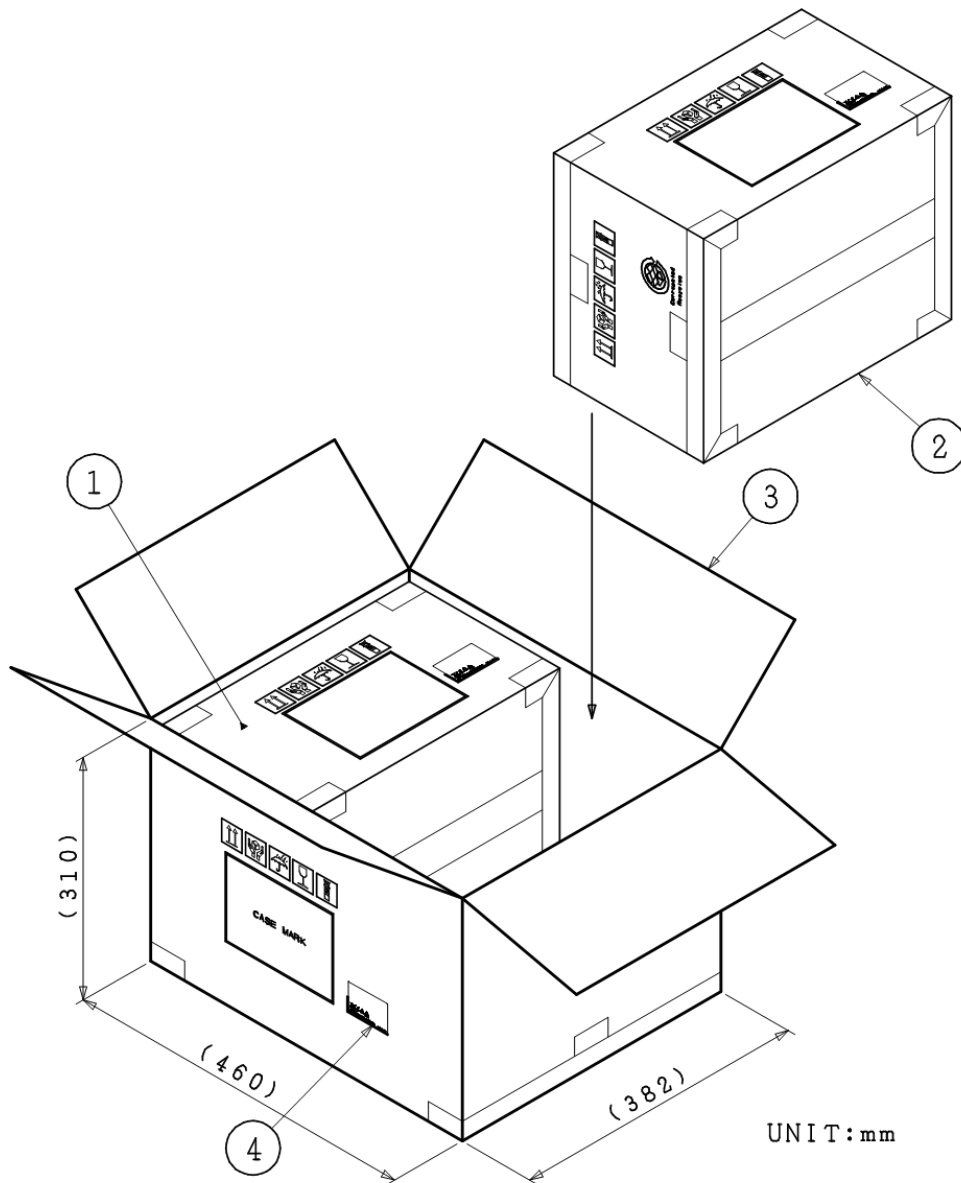

Pictorial Marking for Handling of Goods



THIS WAY UP



FRAGILE



KEEP DRY



HANDLE WITH CARE



LAYERS LIMIT: 3



CORRUGATED RECYCLES

①: BUC

②: AC/DC PSU

③: Double-wall corrugated fiberboard

④: Label

* Above Specifications are subject to change without notice.

Appendix Outdoor 500W AC/DC Power Supply Unit

10. Handling Precautions

10.1. DANGER



This statement indicates an imminently hazardous situation which, if not avoided, will result in death or serious injury.

Items	Description
Input Voltage	<p>Only input a AC voltage within the range indicated in specifications.</p> <p><u>Do</u> operate with the input voltage range between 100 and 240 V AC power with 50/60 Hz of AC frequency.</p> <p>When applying higher voltage than specifications (264 V as absolute maximum rating), it will not only cause this unit failure, but it may also result in <u>electric shock</u> and <u>fire</u>.</p>
Disassembling	<p><u>Do not</u> disassemble the unit.</p> <p>Disassembling will not only cause this unit failure, but it may also result in <u>electric shock</u>.</p>

10.2. WARNING



This statement indicates a potentially hazardous situation which, if not avoided, could result in death or serious injury.

Items	Description
Hot Surface	<p>Whole of body and heat sink is hot when this unit is powered, and even after power is disconnected until it is cooled down.</p> <p><u>Do not</u> touch hot surface to avoid a burn hazard.</p>

* Above Specifications are subject to change without notice.

Appendix Outdoor 500W AC/DC Power Supply Unit

10.3. CAUTION



This statement indicates a potentially hazardous situation which, if not avoided, could result in minor or moderate injury. The statement may also be used to indicate other unsafe practices or risks of property damage.

Items	Description
Fan Rotation	<p><u>Do not</u> insert finger into the fan in every case and time to avoid injury also <u>do not</u> insert any objects into the fan.</p> <p>Keep any objects away from the fan. Incorrect usage may cause injury to self or others.</p>
Connection	<p>DC power of +51 V voltage will output at DC output interface connector. <u>Do not</u> connect the other than cable connected from the +51V operable BUC.</p> <p>The connected equipment may be damaged when cable connecting modem, the BUC other than the +51V operable BUC, or other equipment.</p>

10.4. NOTE



This statement is used to notify of installation, operation, or maintenance information that is important, but not hazard-related.

Items	Description
Mounting	<p><u>Do not</u> block airflow of this unit fan to keep the heat dissipation performance.</p> <p>The install direction and space mentioned at Content 8.3.1 are recommended to secure.</p>
Grounding	<p>To reduce the risk of damage or broken by lightning surge, the unit should be grounded by connecting the ground wire.</p>
Torque Management	<p><u>Do not</u> tighten with excessive torque when attaching screws/bolts.</p> <p>The following value as tighten torque is recommended.</p> <ul style="list-style-type: none"> ■ Screws/Bolts - M4: 1.15 to 1.4 N·m
Weatherproof	<p>The unit mounted in outdoor should be conducted with adequately weatherproof procedure.</p> <p>Install all of mating connectors correctly and securely.</p> <p>Do seal all of cable connection points from the connector to the cable sheath by usage of self-amalgamating tape.</p>
Input Voltage	<p><u>Do</u> operate with the input voltage range between +100 and +240 V AC power.</p> <p>Avoid applying more than the maximum voltage in this range under any conditions.</p>

* Above Specifications are subject to change without notice.

Appendix Outdoor 500W AC/DC Power Supply Unit

Items	Description
High Temperature Operation	It may cause damage and/or degradation of reliability / lifetime to operate the unit in a condition where the ambient temperature exceeds the maximum value, <u>+60 °C</u> , at operating temperature described in the specifications.
Vibration / Shock	When vibration and/or shock impact exceeding the conditions described in the specifications is applied, internal parts may be damaged.
Fan Maintenance	The fan has its lifetime. The fan is to be replaced with a new one at appropriate interval. The recommendation interval of replacement is five(5) years.
Warranty	The unit is covered by a warranty for one(1) year following delivery unless otherwise stipulated in the contract or delivery conditions. Repairs may be possible under payment of charge even for the unit whose warranty period has expired. Opening, removing, disassembling and modifying any parts and components (including the product label, sealing tape and screws) without fan equipment will immediately void the warranty. In any case, the unit of invalid warranty cannot be repaired.

* Above Specifications are subject to change without notice.

Appendix Outdoor 500W AC/DC Power Supply Unit

11. Instructions Manual

11.1. Descriptions

This section describes the information of Connectors and etc.

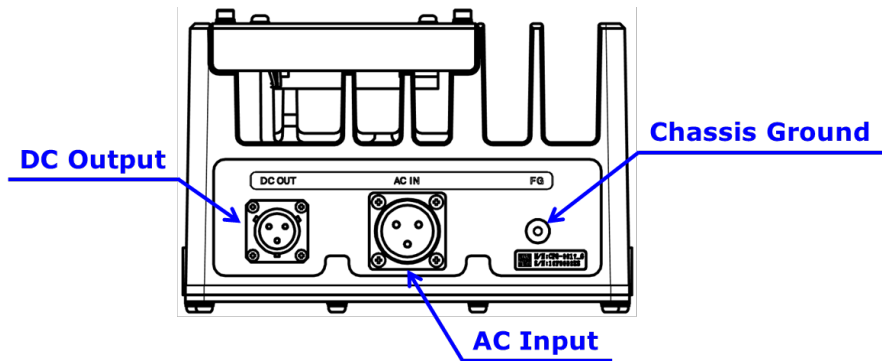

Items	Description	Purpose
AC Input	GTS030-16-10P(025) [Amphenol / 3 pins, male]	100 to 240 V AC power input.
DC Output	PT02E-12-3P(025) [Amphenol / 3 pins, male]	DC power (+51 V nominal) is output
Chassis Ground	M4 Screw Hole	Common chassis ground / frame ground.

11.2. Basic Connection Overview

e.g.) for Ku 40W BUC: NJT8371 series

11.2.1. Connection Overview between BUC and PSU

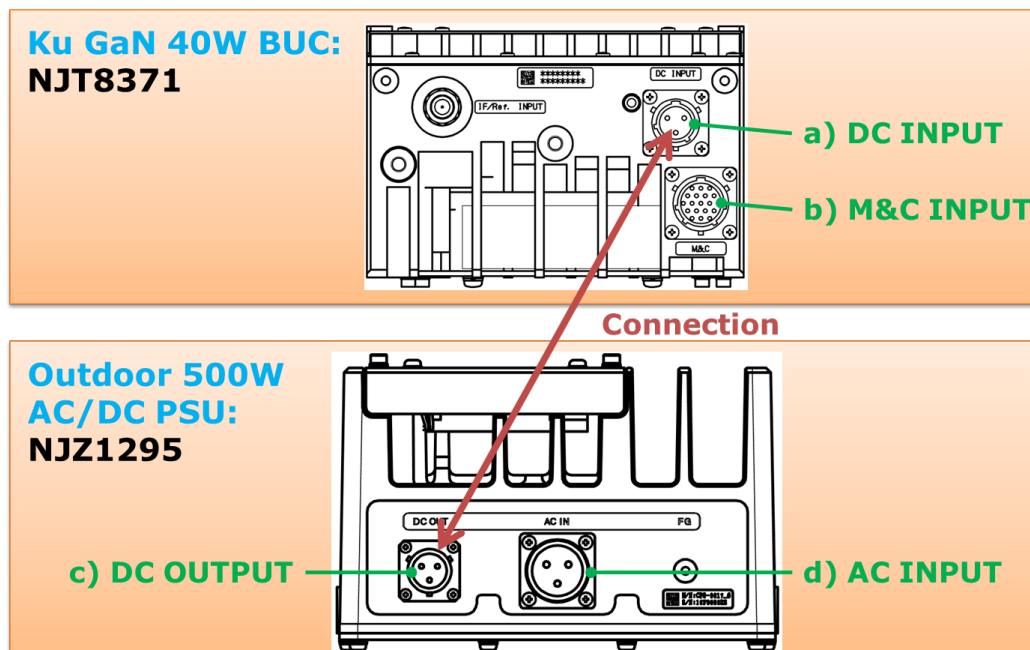

* Above Specifications are subject to change without notice.

Appendix Outdoor 500W AC/DC Power Supply Unit

11.2.2. Connector Pin Assignment

a) DC Input at NJT8371 (Ku 40W BUC)

Unit Connector: PT02E-12-3P(025) [Amphenol / 3 pins, male]

Mating Connector: PT06E-12-3S(470) [Amphenol / 3 sockets, female]

* Mating connector is enclosed in the shipping package of NJT8371

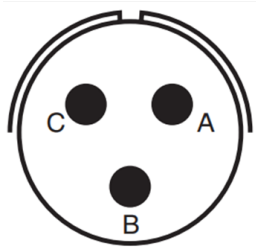

Pin No.	Item	Description
A	DC Input (+)	Prime: +36 to +60 V / DC Voltage
B	Frame GND	GND
C	DC Input (-)	Return

b) M&C Input at NJT8371 (Ku 40W BUC)

Unit Connector: PT02E-14-19P(025) [Amphenol / 19 sockets, male]

Mating Connector: PT06E-14-19S(470) [Amphenol / 19 pins, female]

* Mating connector is enclosed in the shipping package of NJT8371

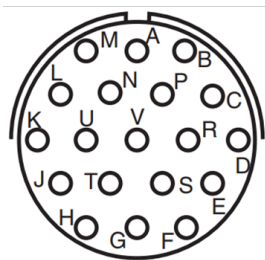

Pin No.	Item	Description
A	GND	GND
B	GND	GND
C	N.C.	-
D	N.C.	-
E	N.C.	-
F	RS-232C GND	RS-232C M&C Interface
G	RS-232C RxD	RS-232C M&C Interface
H	RS-232C TxD	RS-232C M&C Interface
J	N.C.	-
K	N.C.	-
L	N.C.	-
M	N.C.	-
N	N.C.	-
P	N.C.	-
R	N.C.	-
S	N.C.	-
T	N.C.	-
U	N.C.	-
V	N.C.	-

* Above Specifications are subject to change without notice.

Appendix Outdoor 500W AC/DC Power Supply Unit

c) DC Output at NJZ1295 (500W AC/DC PSU)

Unit Connector: PT02E-12-3P(025) [Amphenol / 3 pins, male]

Mating Connector: PT06E-12-3S(470) [Amphenol / 3 sockets, female]

* Mating connector is enclosed in the shipping package of NJZ1295

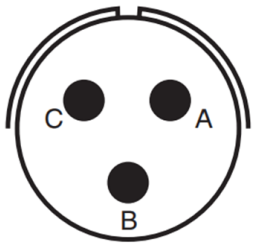

Pin No.	Item	Description
A	DC Input (+)	Prime: 51 V / DC Voltage
B	Frame GND	GND
C	DC Input (-)	Return

d) AC Input at NJZ1295 (500W AC/DC PSU)

Unit Connector: GTS030-16-10P(025) [Amphenol / 3 pins, male]

Mating Connector: GTS06CF-16-10S(025) [Amphenol / 3 sockets, female]

* Mating connector is enclosed in the shipping package of NJZ1295

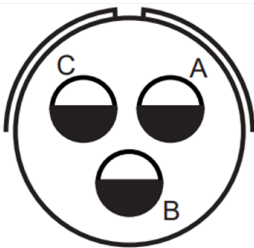

Pin No.	Item	Description
A	AC Input (Live)	100 to 240 V, AC Voltage
B	Frame GND	GND
C	AC Input (Neutral)	100 to 240 V, AC Voltage

11.3. Connection and Installation

This section describes basic installation for the PSU.

* Above Specifications are subject to change without notice.

Appendix Outdoor 500W AC/DC Power Supply Unit

11.3.1. Setting

When installing the PSU, the following guidelines should be complied:

- ✓ Check factors such as accessibility, power, signal, and cable connections and future expansion on the installation location.
- ✓ Plan for access to connector side of the PSU.
- ✓ Ensure the location where the PSU operates has adequate ventilation around the fan intake and exhaust. Ambient air temperature may not cool the PSU to acceptable operating temperatures without adequate ventilation.
- ✓ Arrange the PSU with the install direction and space in below.
- ✓ Available to use the mount bracket for $\Phi 76$ mast as option parts.

Install Direction and Space

The install direction and space in accordance with following are recommended to secure and to keep the heat dispassion performance.

i) Install Direction

a) In case of "Horizontal Direction"

Cooling fan side shall be set to upward direction in below.

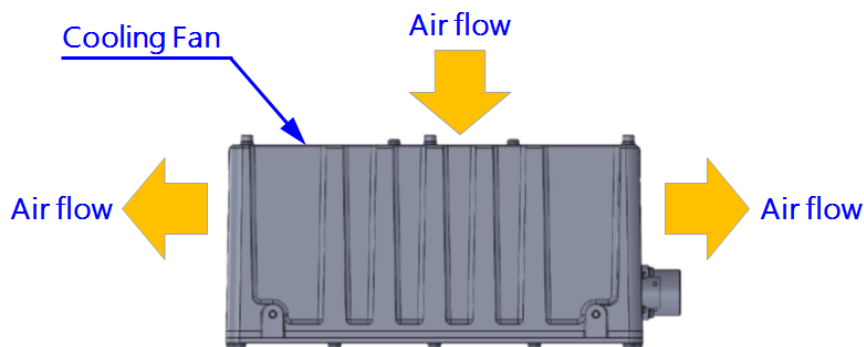

* Above Specifications are subject to change without notice.

Appendix Outdoor 500W AC/DC Power Supply Unit

b) In case of "Vertical Direction"

Connector side shall be set to downward direction in below.

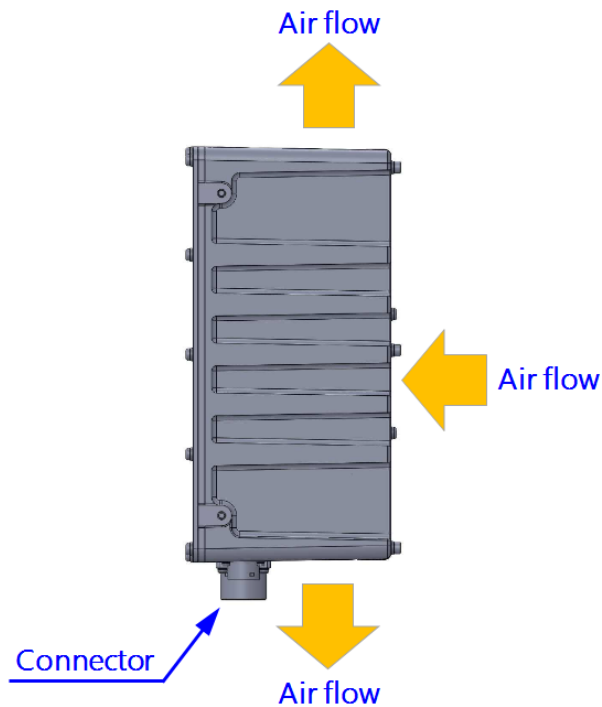

ii) Space

More than 30mm of space at least from inlet/outlet of cooling fan must be reserved.

! N O T E

- ✓ Do not block airflow of this unit fan to keep the heat dissipation performance.
The install direction and space mentioned are recommended to secure.

* Above Specifications are subject to change without notice.

Appendix Outdoor 500W AC/DC Power Supply Unit

11.3.2. Connection

Two cables and one wire:

- AC Power Cable
- DC Power Cable between the PSU and BUC
- Wire for Common Chassis Ground / Frame Ground

1) AC Power Cable

The PSU is directly powered by AC power source (100-240V). Low noise / low transient AC power source is recommended.

The connection of AC power cable should be complied with the following steps:

Step 1: Assemble the AC power cable. Use a power cable with an outer diameter (O.D.) of 9 - 13 mm to properly assemble the mating connector (Model: GTS06CF-16-10S(025)) included in the shipment package. The connector pin assignment should be referred in Item (d) of Section 8.2.2. The assembly method of mating connector is referred to appendix. The appropriate three-plug terminal should be selected according to the outlet shape to be used, and assembled to the power cable at the opposite side of the mating connector.

It is available to purchase the AC power cable of P/N: NJZ1290A03 as option part.

Step 2: Connect the mating connector (Model: GTS06CF-16-10S(025)) of the AC power cable to the connector of AC Input of the PSU correctly and securely. And for to harden the waterproof structure it is recommended that a cable connection point from the connector to the cable sheath is sealed by usage of self-amalgamating tape.

Do not connect the AC power cable to the AC outlet before all of other connection steps.

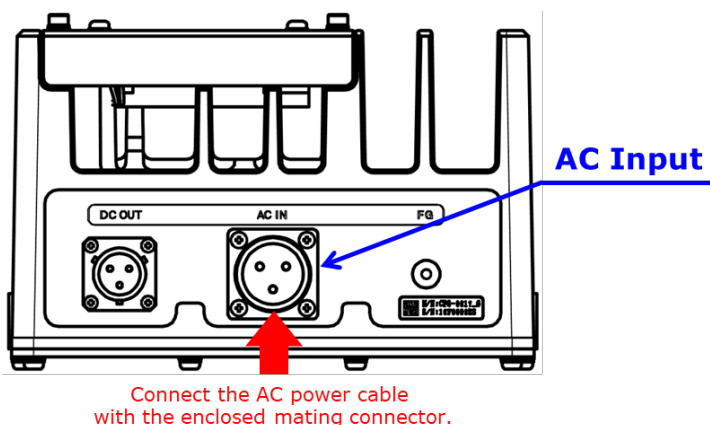

* Above Specifications are subject to change without notice.

Appendix Outdoor 500W AC/DC Power Supply Unit

2) DC Power Cable between the PSU and BUC

The PSU supplies +51V DC power to BUC through this connection cable.

The connection of the DC power cable between the PSU and BUC should be complied with the following steps:

Step 1: Assemble the DC power cable. Use a power cable with an outer diameter (O.D.) of 10.9 mm. The cable length should refer to Section 8.3.4, and for the decision of cable length it is needed to consider the voltage drop due to the conductor resistance of the wires. Properly assemble the mating connector (Model: PT06E-12-3S(470)) included in the shipment package of the PSU to the power cable. Properly assemble the mating connector (Model: PT06E-12-3S(470)) included in the shipment package of the BUC to the opposite side of the aforementioned power cable. The pin assignment of connectors should be referred in Item (a) and (c) of Section 8.2. The assembly method of mating connector is referred to appendix.

It is available to purchase the DC power cable of P/N: NJZ1290A04 as option part.

Step 2: Connect the appropriate mating connector (Model: PT06E-12-3S(470)) of the DC power cable to the connector of DC Output at the PSU correctly and securely. And for to harden the waterproof structure it is recommended that a cable connection point from the connector to the cable sheath is sealed by usage of self-amalgamating tape.

Step 3: Connect the appropriate mating connector (Model: PT06E-12-3S(470)) of the DC power cable to the connector of DC Input at the BUC correctly and securely. And for to harden the waterproof structure it is recommended that a cable connection point from the connector to the cable sheath is sealed by usage of self-amalgamating tape.

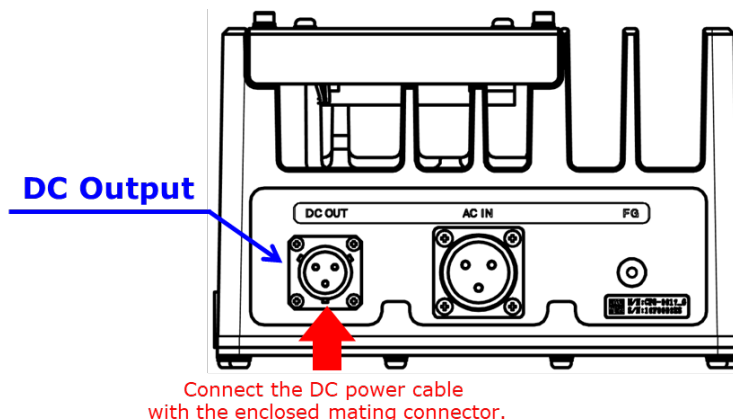

* Above Specifications are subject to change without notice.

Appendix Outdoor 500W AC/DC Power Supply Unit

3) Wire for Common Chassis Ground / Frame Ground

The PSU can be had the chassis ground of the other equipment (e.g. modem) in common. Connecting wire for common chassis ground from the chassis ground of the other equipment should be complied with the following step:

Tools Required: #2 Phillips screwdriver

Step: Connect the wire from ground on the other equipment to the ground hole with M4 x 8 mm Philips pan head screw.

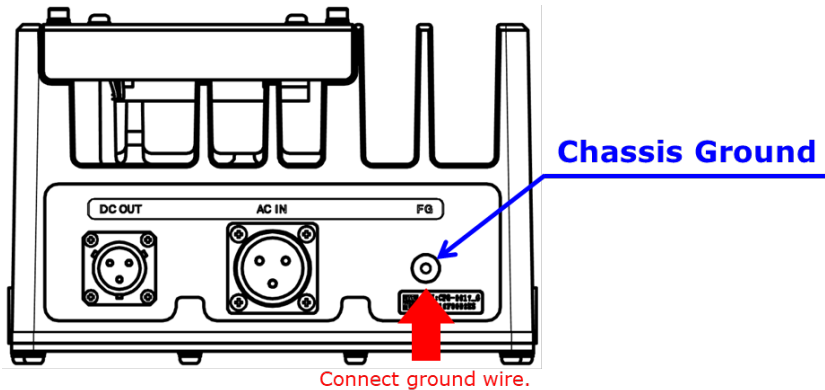

CAUTION

- ✓ DC power of +51 V will output at DC output interface connector. Do not connect the other than cable connected from the +51V operable BUC. The connected equipment may be damaged when cable connecting modem, the BUC other than the +51V operable BUC, or other equipment.

NOTE

- ✓ Do not connect the AC power cable to the AC outlet before all of other connection steps.
- ✓ To reduce the risk of damage or broken by lightning surge, the unit should be grounded by connecting the ground wire.
- ✓ Do operate with the input voltage range between +100 and +240 V AC power. Avoid applying more than the maximum voltage in this range under any conditions.
- ✓ Do seal all of cable connection points from the connector to the cable sheath by usage of self-amalgamating tape for to harden the waterproof structure.

* Above Specifications are subject to change without notice.

Appendix Outdoor 500W AC/DC Power Supply Unit

11.3.3. Start-up

Start-up will be immediately performed with the following step:

Step: Connect the AC power cable to the AC outlet

11.3.4. Recommendation Cable between PSU to BUC

Type and length of the signal cable from the PSU to BUC need to be chosen to satisfy that the PSU output less than 500 W DC power, and an input voltage of BUC is more than input minimum voltage such as 36 V.

The chart for total resistance* and maximum length is referred in below.

BUC Model	DC Power Requirement of BUC		Total Resistance	Maximum Length		
	Minimum Input Voltage	Maximum Power Consumption		0.5 SQ Wire Cable	0.75 SQ Wire Cable	1.25 SQ Wire Cable
NJT8371 series	+36 V	290 W	1.8 Ω	---	34 m	56 m

(*Note: Total resistance means sum number of both prime wire and return wire resistance.)

11.4. Maintenance

This section describes basic maintenance for the PSU.

11.4.1. Dust Removal

Regular dusting / dust removal will ensure the PSU to operate within operational specification.

- ✓ Use a slightly damp cloth with excess moisture wringed out (not saturated, wet or dripping cloth) to wipe away the dust that collects on the outside of the enclosure
- ✓ A high, dusty environment will require frequent maintenance of vacuuming the dust off the enclosure vents and circuit board.

w

11.4.2. Fan Field Replacement

The PSU requires to flow forced-air by the installed fan on rear panel for cooling.

It is recommended that the fan is to be replaced with a new one at five years interval.

NOTE

✓ The fan has its lifetime. The fan is to be replaced with a new one at appropriate interval. The recommendation interval of replacement is 5 years.

* Above Specifications are subject to change without notice.

Appendix Outdoor 500W AC/DC Power Supply Unit

The replacement of fan should be complied with the following steps:

Tools Required: Hex Wrench for M4 (size: 3 mm)

Parts Required: Replacement Fan - P/N: NJZ1290F06

Step 1: Remove the hexagon socket head bolts (6 pieces) shown in Fig. 8.4.2.1.

These bolts are reused when installing the replacement fan. Please be careful not to lose them. When using different bolts, following equivalents should be used.

M4 x 8 Hexagon Socket Head Bolts with Washer and Spring W (SUS, Chrome plating treatment)

Step 2: Dismount the fan unit which is together with the fan and fan intake cover, and a fan connecting position should be checked (Refer to Fig. 8.4.2.2)

Do not pull the fan unit strongly because the fan cable is connected.

Step 3: Release the connector lock by pushing the locker hook in the direction of an arrow shown in Fig. 8.4.2.3.1.

Step 4: Pull out the fan cable from the connector in the direction of an arrow shown in Fig. 8.4.2.3.2.

Hold the connector body and pull it. **Do not pull on the cable.** When the connector lock is released normally, the connector can be pulled out with a weak force.

Step 5: After removing the fan unit in step 1-to-4, install the replacement fan unit in the reverse order of step 1-to-4

The connector shall be inserted securely until it is locked.

Recommended tighten torque of M4 bolts is 1.6 +/- 0.2 N·m.

Hexagon Socket Head Bolts

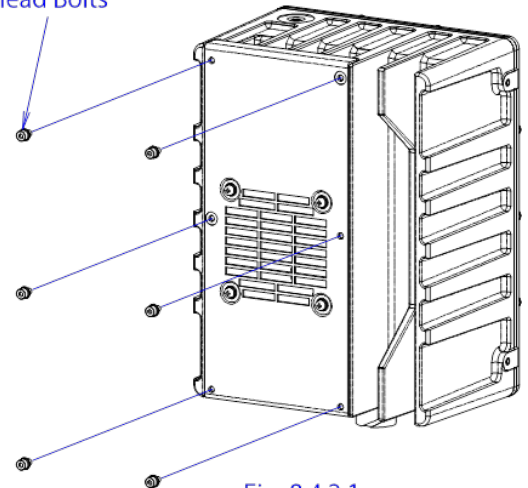
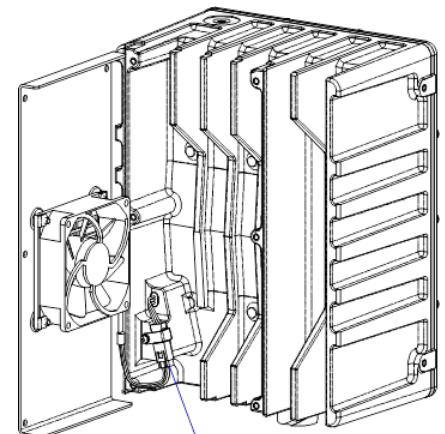

Fig. 8.4.2.1



Fan Connector

Fig. 8.4.2.2

Locker Hook

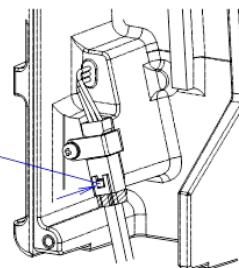

Fig. 8.4.2.3.1
(Connector Enlarged)

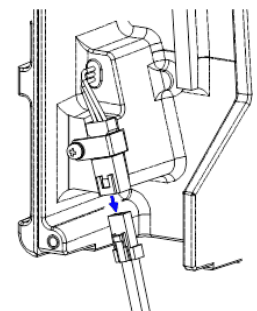

Fig. 8.4.2.3.2
(Connector Enlarged)

* Above Specifications are subject to change without notice.

Appendix Outdoor 500W AC/DC Power Supply Unit

12. Option Parts

- 12.1. AC Power Cable - P/N: NJZ1290A03
 Connection Cable between the PSU (NJZ1295) and AC Outlet
- ✓ Length: 3m
 - ✓ Weatherized Cable
 - ✓ AC Mating Connector Assembled
 - ✓ No Assembly at AC Outlet Side

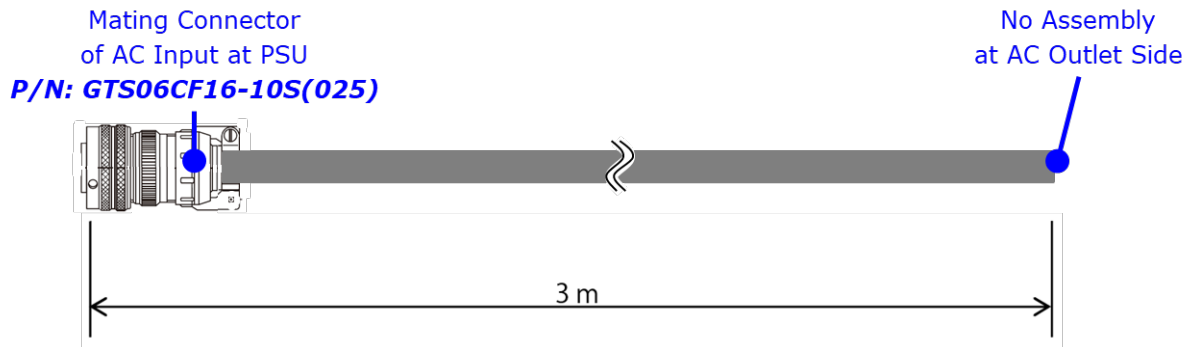

- 12.2. DC Power Cable - P/N: NJZ1290A04
 Connection Cable between the BUC and the PSU (NJZ1295)
- ✓ Length: 5m
 - ✓ Weatherized Cable
 - ✓ Two Mating Connectors Assembled

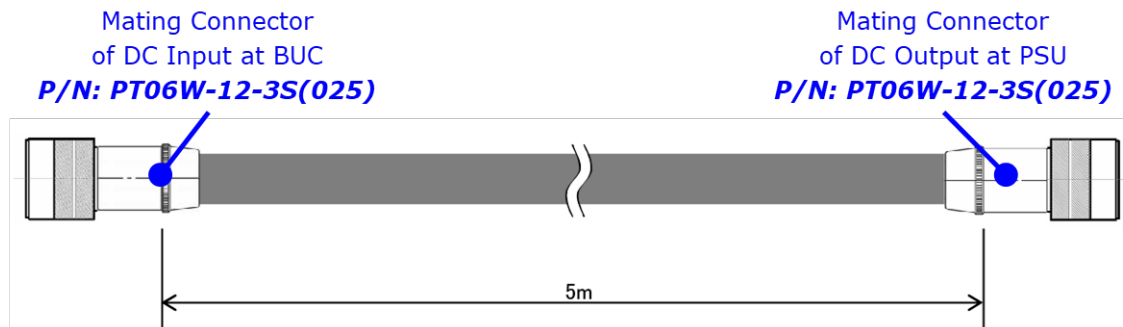

* Above Specifications are subject to change without notice.

Appendix Outdoor 500W AC/DC Power Supply Unit

12.3. Mount Bracket for $\Phi 76$ Mast - P/N: NJZ1290D04

This option part is to mount the PSU to $\Phi 76$ Mast.

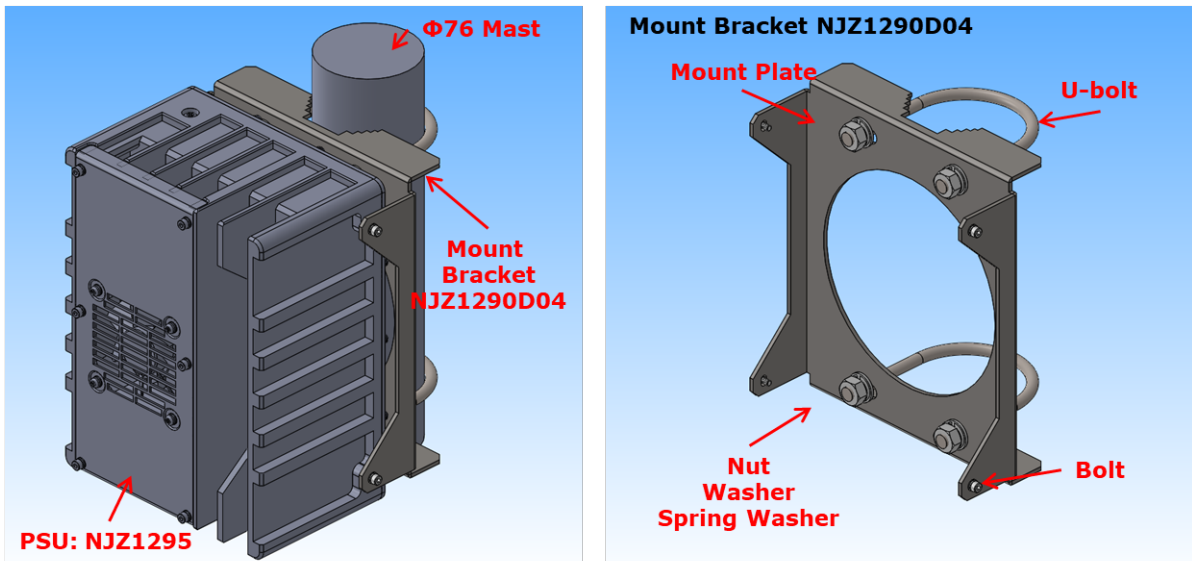

Item	Qty	Description
Mount Plate	1	SUS
Bolt	4	SUS, M4, with W & SW, for fixing PSU
U-bolt	2	SUS, 65A(2-1/2"), M10
Nut	4	SUS, M10
Washer	4	SUS, for M10
Spring Washer	4	SUS, for M10

12.4. Replacement Fan Kit- P/N: NJZ1290F06

This option part is to replace the cooling fan.

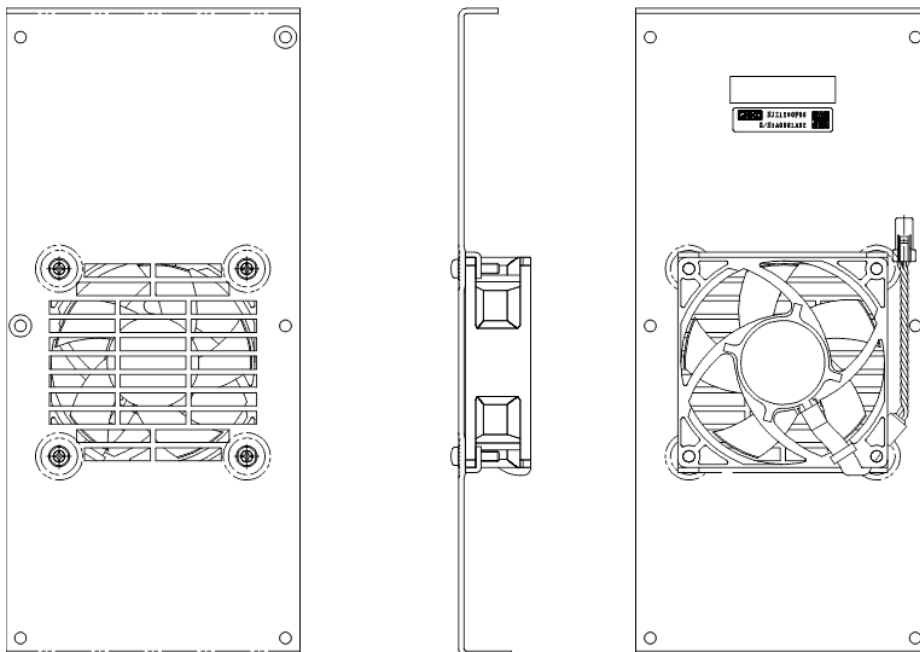

* Above Specifications are subject to change without notice.

Appendix Cable Assembly of Mating Connector

This appendix mentions about cable assembly of mating connector.

Cable Assembly of Mating Connector for GT Series and PT Series Connector

* Above Specifications are subject to change without notice.

Appendix Cable Assembly of Mating Connector

1. Amphenol GT Series Connector

Applicable Connector:

- GTS06CF-16-10S(025) for AC Input at PSU

Assembly Procedure Steps:

Step 1: Prepare a signal cable with the wanted length. Use the cable with core wire conductor size and an outer diameter (O.D.) in below.

GTS06CF-16-10S(025)	
Layout / Pin Assignment (Mating face view of pin inserts) Contact Type:  = #12	
Shell Size	Shell-16
Contact Number	3 contacts - #12
Outer Diameter	9 to 13 mm
Contact Type	#12
Wire Size	AWG #12 to #14
Wire Stripping Length	10.5 mm

Table 1 Description of Connector / Cable / Wire

Step 2: Strip the outer sheath and filler with approx. 16.6 mm and strip the wire insulations with Wire Stripping Length by wire-stripper in Table 1. Treat the stripped wires with Rosin-flux of within-expired-date and immediately pre-solder the stripped wires with Rosin core solder.

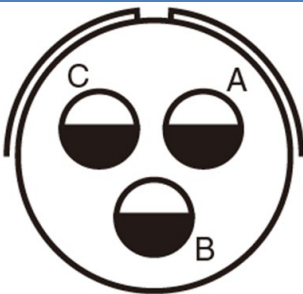
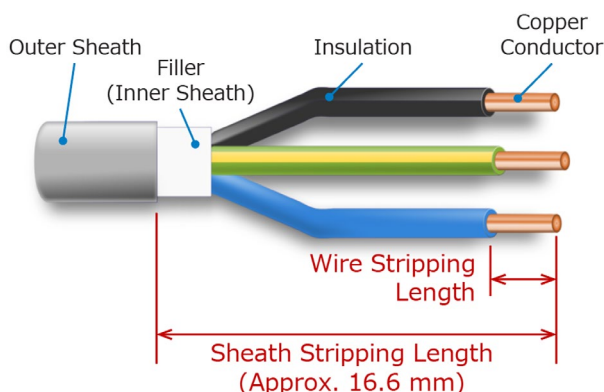

* Above Specifications are subject to change without notice.

Appendix Cable Assembly of Mating Connector

! NOTE

- ✓ Notice that any damage of the wire insulations when stripping the outer sheath and filler shall be avoided.

Step 3: Disassembly a cable clamp, metal compression disc, neoprene sealing gland and backshell from the connector body. **Do not disassembly a coupling nut, wave spring and skid washer form a barrel.**

Insert the cable clamp, metal compression disc, neoprene sealing gland and backshell to the prepared AC power cable in the order of the cable clamp, metal compression disc, neoprene sealing gland and backshell.

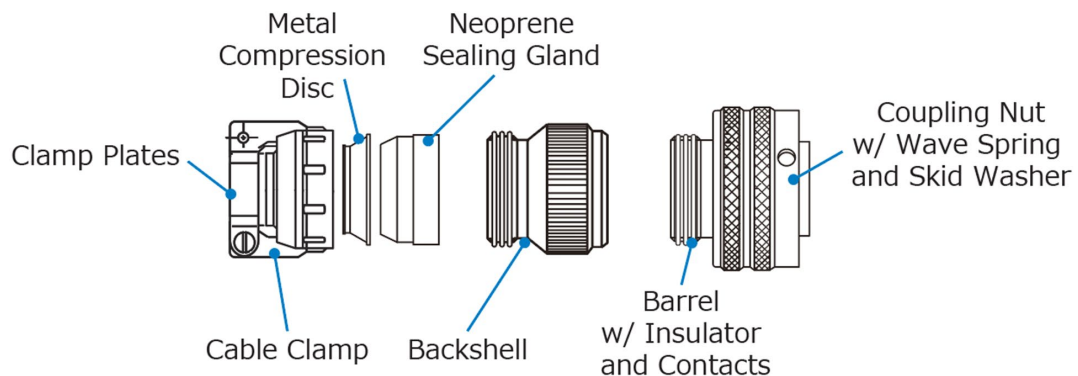

Step 4: Solder all of contacts and wires under condition with the pin assignment. It is recommended to arrange so that the contact cuts are upward for easy-soldering. Cleanse the flux at soldering points with ethyl-alcohol and etc.

! NOTE

- ✓ Notice that insulator at the barrel shall be avoided to deform.

Step 5: Tighten the backshell to the barrel with following torque.

Slide the neoprene sealing gland to the backshell until it hits the back of the backshell, and slide the metal compression disc to the neoprene sealing gland.

Tighten the cable clamp to the barrel with following torque.

Clamp the cable with two clamp plates, which will be fixed with enclosed flat head screws to the cable clamp.

Shell Size	Tighten Torque	Connector P/N
Shell-16	3.9 to 5.1 N·m	GTS06CF-16-10S(025)

* Above Specifications are subject to change without notice.

Appendix Cable Assembly of Mating Connector

2. Amphenol PT Series Connector

Applicable Connector:

- PT06E-12-3S(470) for DC Output at PSU and DC Input at BUC

Assembly Procedure Steps:

Step 1: Prepare a signal cable with the wanted length. Use the cable with core wire conductor size and an outer diameter (O.D.) in below.

PT06E-12-3S(470)	
Layout / Pin Assignment (Mating face view of pin inserts)	
Contact Type: ○ = #20 ● = #16	
Shell Size	Shell-12
Contact Number	3 contacts - #16
Outer Diameter	10.9 mm max.
Contact Type #16	
Wire Size	AWG #16 to #18
Wire Stripping Length	5.3 to 5.8 mm

Table 1 Description of Connector / Cable / Wire

Step 2: Strip the outer sheath and filler with up to 50 mm and strip the wire insulations with Wire Stripping Length by wire-stripper in Table 1. Treat the stripped wires with Rosin-flux of within-expired-date and immediately pre-solder the stripped wires with Rosin core solder.

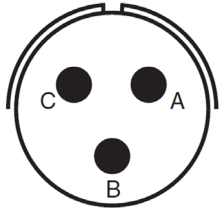
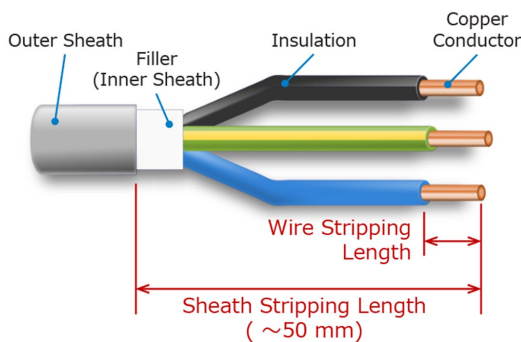

! NOTE

- ✓ Notice that any damage of the wire insulations when stripping the outer sheath and filler shall be avoided.

* Above Specifications are subject to change without notice.

Appendix Cable Assembly of Mating Connector

Step 3: Disassembly a cable clamp, endbell, compression ring, and grommet from the connector body.

Insert the cable clamp, endbell, and compression ring to the prepared signal cable in the order of the cable clamp, endbell, and compression ring.

Insert wires to the grommet under condition matched the pin assignment of contacts and wires.

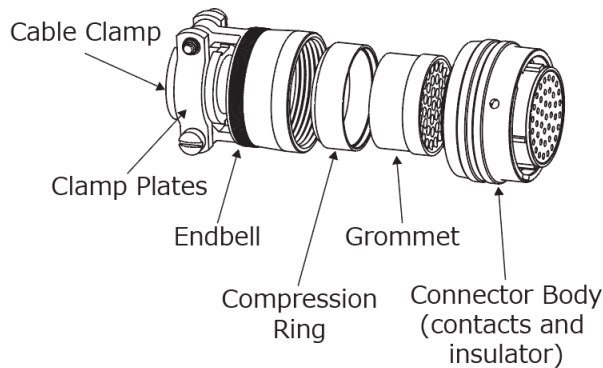

Step 4: Solder all of contacts and wires under condition with the pin assignment. It is recommended to arrange so that the contact cuts are upward for easy-soldering.

Cleanse the flux at soldering points with ethyl-alcohol and etc.

NOTE

✓ Notice that insulator of the connector body shall be avoided to deform.

Step 5: Slide the grommet to the connector body until it hits the back of the insulator, and insert the compression ring to the step edge of the grommet.

Tighten the endbell to the connector body with following torque met for shell size.

Shell Size	Tighten Torque	Connector P/N
Shell-12	3.5 to 4 N·m	PT06E-12-3S(470)

When a gap between the cable clamp and wires is 1 mm or more, wrap wires at the cable clamp point with a self-amalgamating tape so that the gap is 1 mm or less. Set the cable clamp at wires of the cable clamp point. And clamp the cable clamp with two clamp plates, which will be fixed with enclosed flat head screws to the endbell.

Wrap both the cable and connector with a self-amalgamating tape from outer sheath of cable to the middle of endbell like as shown in the range of arrows in following image.

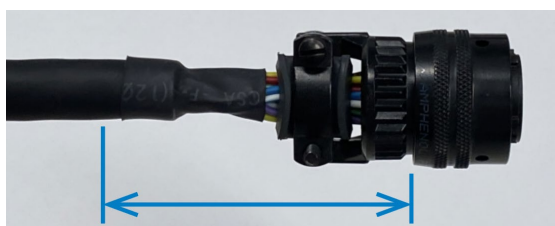

* Above Specifications are subject to change without notice.

Appendix Specifications of Monitor & Control

This appendix mentions about specifications of monitor & control for M&C option.

Rev. 1.2

Issued on July 16, 2016

Specifications of Monitor & Control (M&C) for Ku-band GaN 40W BUC: NJT8371 series

* Above Specifications are subject to change without notice.

Appendix Specifications of Monitor & Control

1. Interface Specifications

1.1. FSK Communications M&C

- | | |
|-------------------------|---|
| (1) Physical Interface | IF Connector: N-type or F-type, female
Combine with IF signal and 10MHz Reference signal |
| (2) Transmitter Outputs | |
| a. Frequency | 650 kHz +/- 5% |
| b. FSK deviation | +/-60 kHz nom. (+60 kHz mark) |
| c. Deviation tolerance | +/-50 kHz min., +/-70 kHz max. |
| d. Output Level | -10 dBm nom. |
| e. Output impedance | 50 Ω |
| f. Start Tone | 710 kHz (mark) / 10ms min |
| (3) Receiver Inputs | |
| a. Locking range | ± 32.5 kHz |
| b. Input impedance | 50 Ω |
| c. Input Sensitivity | -15 dBm min. |

1.2. RS-232C Interface M&C

- | | |
|------------------------|---|
| (1) Physical Interface | Circular Connector: P/N PT02E-14-19P (025)
Pin Assignment: |
|------------------------|---|

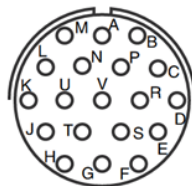

- Pin A: GND COMMON**
- Pin B: GND COMMON**
- Pin C: N.C.**
- Pin D: N.C.**
- Pin E: N.C.**
- Pin F: GND COMMON**
- Pin G: RS-232C RxD**
- Pin H: RS-232C TxD**
- Pin J: N.C.**
- Pin K: N.C.**
- Pin L: N.C.**
- Pin M: N.C.**
- Pin N: N.C.**
- Pin P: N.C.**
- Pin R: N.C.**
- Pin S: N.C.**
- Pin T: N.C.**
- Pin U: N.C.**
- Pin V: N.C.**

- | | |
|-------------------------|-----------------------|
| (2) Transmitter Outputs | |
| a. Output Voltage Swing | ±5V min. / ±5.4V typ. |
| b. Output Resistance | 300Ω min. / 10MΩ typ. |

* Above Specifications are subject to change without notice.

Appendix Specifications of Monitor & Control

(3) Receiver Inputs

- | | |
|-------------------------|-------------|
| a. Input Voltage Range | ±15 V |
| b. Input Threshold low | +0.6 V min. |
| c. Input Threshold High | +2.4 V max |
| d. Input Resistance | 7 kΩ max |

2. Transmission Protocol

- | | |
|-------------------|---|
| a. Operation Mode | Binary |
| b. Transfer Rate | 9600 bit/s |
| c. Data Format | 1 start bit, 8 data bits, 1 stop bit, No Parity |

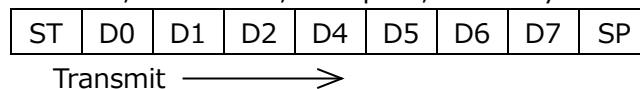

The least significant bit (LSB) is sent first.

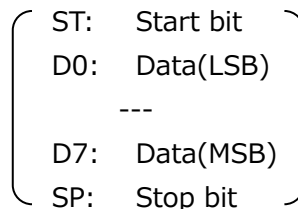

- | | |
|--------------------------|---------------|
| d. Maximum Response Time | 50 ms |
| e. Message Rate | 1 every 20 ms |

3. Packet Format

- | | |
|-----------------------|---------|
| a. Data Packet Length | 7 Bytes |
| b. Byte Configuration | |

Byte	Command (IDU to BUC)	Response (BUC to IDU)
1 st	BUC Address ^{*1}	BUC Address ^{*2}
2 nd	Command	Data Byte 1
3 rd	Data Byte 1	Data Byte 2
4 th	Data Byte 2	Data Byte 3
5 th	Data Byte 3	Data Byte 4
6 th	Data Byte 4	Data Byte 5
7 th	Checksum ^{*3}	Checksum ^{*3}

^{*1}: Initial setting of a BUC address is 0x01.

^{*2}: Responder address is shifted left by 4 bits.

^{*3}: Algebraic sum of bytes 1 through 6.

Note: Spare bytes are always filled with 0xAA (10101010).

* Above Specifications are subject to change without notice.

Appendix Specifications of Monitor & Control

4. Command & Response Message Structure

The BUC status is stored to internal EEPROM.

The last BUC state is stored to internal EEPROM, so when the BUC is re-turned DC power on again, the state is reproduced last BUC condition.

4.1. Command Message Structure (IDU to BUC)

a. Request Status

This command can acquire output power level, alarm status, BUC class, and temperature etc.

Byte	Name	Description	Value
1 st	Address	BUC Address	0x01 (to 0x0F)
2 nd	Command	Request Status	0x01
3 rd	Data Byte 1	Not used	0xAA
4 th	Data Byte 2	Not used	0xAA
5 th	Data Byte 3	Not used	0xAA
6 th	Data Byte 4	Not used	0xAA
7 th	Checksum	Algebraic sum of bytes 1 - 6	

e.g.)

0x01	0x01	0xAA	0xAA	0xAA	0xAA	CHK
------	------	------	------	------	------	-----

b. Set Transmit On/Off State

This command can set a state of transmit on and transmit off

Byte	Name	Description	Value
1 st	Address	BUC Address	0x01 (to 0x0F)
2 nd	Command	Set Transmit On/Off State	0x02
3 rd	Data Byte 1	Tx Control	Off: 0x00 / On: 0x01
4 th	Data Byte 2	Not used	0xAA
5 th	Data Byte 3	Not used	0xAA
6 th	Data Byte 4	Not used	0xAA
7 th	Checksum	Algebraic sum of bytes 1 - 6	

e.g.)

0x01	0x02	0x01	0xAA	0xAA	0xAA	CHK
------	------	------	------	------	------	-----

* Above Specifications are subject to change without notice.

Appendix Specifications of Monitor & Control

c. Set Attenuator

This command can set the step attenuator with 0.5 dB step in the BUC.

Byte	Name	Description	Value
1 st	Address	BUC Address	0x01 (to 0x0F)
2 nd	Command	Set Attenuator	0x05
3 rd	Data Byte 1	Attenuator Selection 1 or 2	Att.1 0x01 Att.2 0x02 *1
4 th	Data Byte 2	Setting Att. in 10dB digit	0x00 or 0x01 *2
5 th	Data Byte 3	Setting Att. in 1dB digit	0x00 to 0x09 *2
6 th	Data Byte 4	Setting Att. bit in 0.5dB digit	0x00 or 0x05 *2
7 th	Checksum	Algebraic sum of bytes 1 - 6	

e.g.)

0x01	0x05	0x01	0x01	0x02	0x05	CHK
------	------	------	------	------	------	-----

*1: Att.1 is available, Att.2 is not available.

*2: Dynamic range and step size of the step attenuator: 31.5dB in 0.5dB step

ex) 12.5dB : Data byte 2 is 0x01

Data byte 3 is 0x02

Data byte 4 is 0x05

d. Get Attenuator

This command can check the step attenuator setting value in the BUC.

Byte	Name	Description	Value
1 st	Address	BUC Address	0x01 (to 0x0F)
2 nd	Command	Get Attenuator	0x06
3 rd	Data Byte 1	Attenuator Selection 1 or 2	Att.1 0x01 Att.2 0x02 *1
4 th	Data Byte 2	Not used	0xAA
5 th	Data Byte 3	Not used	0xAA
6 th	Data Byte 4	Not used	0xAA
7 th	Checksum	Algebraic sum of bytes 1 - 6	

e.g.)

0x01	0x06	0x01	0xAA	0xAA	0xAA	CHK
------	------	------	------	------	------	-----

*1: Att.1 is available, Att.2 is not available.

* Above Specifications are subject to change without notice.

Appendix Specifications of Monitor & Control

4.2. Response Message Structure (BUC to IDU)

a. Request Status

Byte	Name	Description	Value
1 st	Address	BUC Address shifted left by 4 bits	0x10 (to 0xF0)
2 nd	Level Byte 1	MS byte of Tx Output Power Monitor	*1
3 rd	Level Byte 2	LS byte of Tx Output Power Monitor	
4 th	Temperature	Temperature in deg. C	*2
5 th	Status Byte 1 *3	Bit 0: Temperature Out-of-Range	1: Fail 0: Normal
		Bit 1: PLL Out-of-Lock	1: Fail 0: Normal
		Bit 2: Checksum Error	1: Error 0: Normal
		Bit 3: Tx Status	1: Tx On 0: Tx Off
		Bits 4-7: BUC Power Class	0x1 to 0xA
6 th	Status Byte 2	Bits 0-3: Not used	0xA (Fixed)
		Bits 4-7: Software Version	0x0 to 0xF
7 th	Checksum	Algebraic sum of bytes 1 - 6	

e.g.)

0x10	0x11	0xC6	0xD8	0x98	0x1A	CHK
------	------	------	------	------	------	-----

*1: Data Field Definition for Tx Output Power

Output power is the number which changed hexadecimal data into the decimal number and was divided by 100.

e.g.)

Output Power Data			Output Power
Level Byte 1 is 0x11	}	0x11C6	→ 4550 (decimal)
Level Byte 2 is 0xC6			

*2: Data Field Definition for Temperature

Temperature data is from -128 °C to +127 °C in two's complement (1 °C step).

- e.g.)
- Byte of Temperature is 0xD8 → 11011000 = -40 °C
 - Byte of Temperature is 0xFF → 11111111 = -1 °C
 - Byte of Temperature is 0x40 → 01000000 = 64 °C

* Above Specifications are subject to change without notice.

Appendix Specifications of Monitor & Control

*3: Data Field Definition for Status Byte 1

e.g.) Status Byte 1 is 0x98

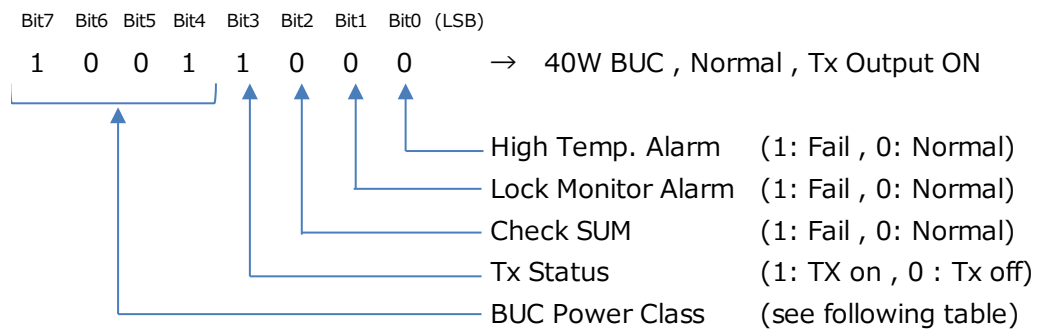

Table: BUC Power Class

Value	0x1	0x2	0x3	0x4	0x5	0x6	0x7	0x8	0x9	0xA
Power Class	2W	4W	5W	8W	10W	16W	20W	25W	40W	60W

*4: Data Field Definition for Status Byte 2

e.g.) Status Byte 2 is 0x1A → Firmware Version Ver.1

b. Set Transmit On/Off State

Byte	Name	Description	Value
1 st	Address	BUC Address shifted left by 4 bits	0x10 (to 0xF0)
2 nd	Data Byte 1	Tx Control	Off: 0x00 / On: 0x01
3 rd	Data Byte 2	Not used	0xAA
4 th	Data Byte 3	Not used	0xAA
5 th	Data Byte 4	Not used	0xAA
6 th	Data Byte 5	Not used	0xAA
7 th	Checksum	Algebraic sum of bytes 1 - 6	

e.g.)

0x10	0x01	0xAA	0xAA	0xAA	0xAA	CHK
------	------	------	------	------	------	-----

* Above Specifications are subject to change without notice.

Appendix Specifications of Monitor & Control

c. Set Attenuator

Byte	Name	Description	Value
1 st	Address	BUC Address shifted left by 4 bits	0x10 (to 0xF0)
2 nd	Data Byte 1	Attenuator Selection 1 or 2	Att.1 0x01 Att.2 0x02 *1
3 rd	Data Byte 2	Set Att. bit in 10 dB digit	0x00 or 0x01
4 th	Data Byte 3	Set Att. bit in 1 dB digit	0x00 to 0x09
5 th	Data Byte 4	Set Att. bit in 0.5 dB digit	0x00 or 0x05
6 th	Data Byte 5	Not used	0xAA
7 th	Checksum	Algebraic sum of bytes 1 - 6	

d.

e.g.)

0x10	0x01	0x01	0x02	0x05	0xAA	CHK
------	------	------	------	------	------	-----

*1: Att.1 is available, Att.2 is not available.

d. Get Attenuator

Byte	Name	Description	Value
1 st	Address	BUC Address shifted left by 4 bits	0x10 (to 0xF0)
2 nd	Data Byte 1	Attenuator Selection 1 or 2	Att.1 0x01 Att.2 0x02 *1
3 rd	Data Byte 2	Set Att. bit in 10 dB digit	0x00 or 0x01
4 th	Data Byte 3	Set Att. bit in 1 dB digit	0x00 to 0x09
5 th	Data Byte 4	Set Att. bit in 0.5 dB digit	0x00 or 0x05
6 th	Data Byte 5	Not used	0xAA
7 th	Checksum	Algebraic sum of bytes 1 - 6	

e.

e.g.)

0x10	0x01	0x01	0x02	0x05	0xAA	CHK
------	------	------	------	------	------	-----

*1: Att.1 is available, Att.2 is not available.

* Above Specifications are subject to change without notice.